

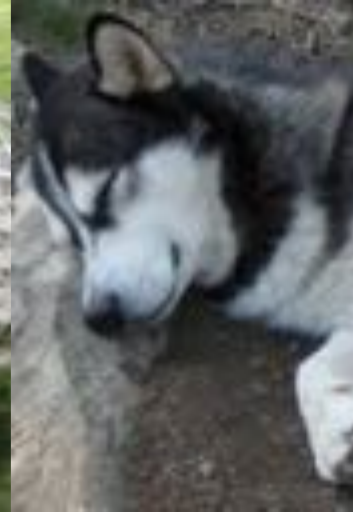

Networks and Hierarchical Processing: Object Recognition in Human and Computer Vision

Guest Lecture: Marius Cătălin Jordan
CS 131 - Computer Vision: Foundations and Applications
01 December 2014



1. Processing Pathways in the Human Visual System

- “what” and “where” pathways
- building features in the ventral stream

2. Hierarchical Pattern Recognition Systems

- early stages: small scale neural network
- injecting neuroscience knowledge into design

3. Third Age of the Neural Network: Modern Deep Nets

- extremely large scale (data + computation)
- sudden, huge performance boost for recognition

From Retina to Cortex

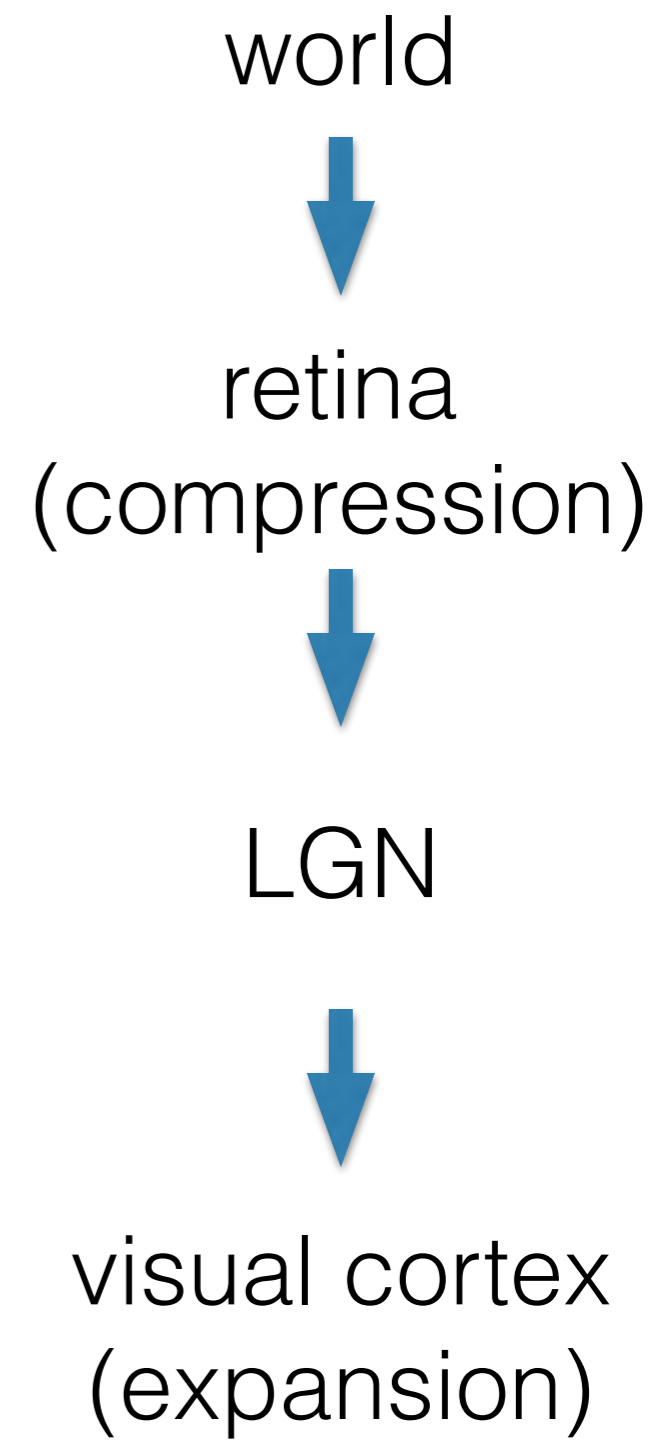
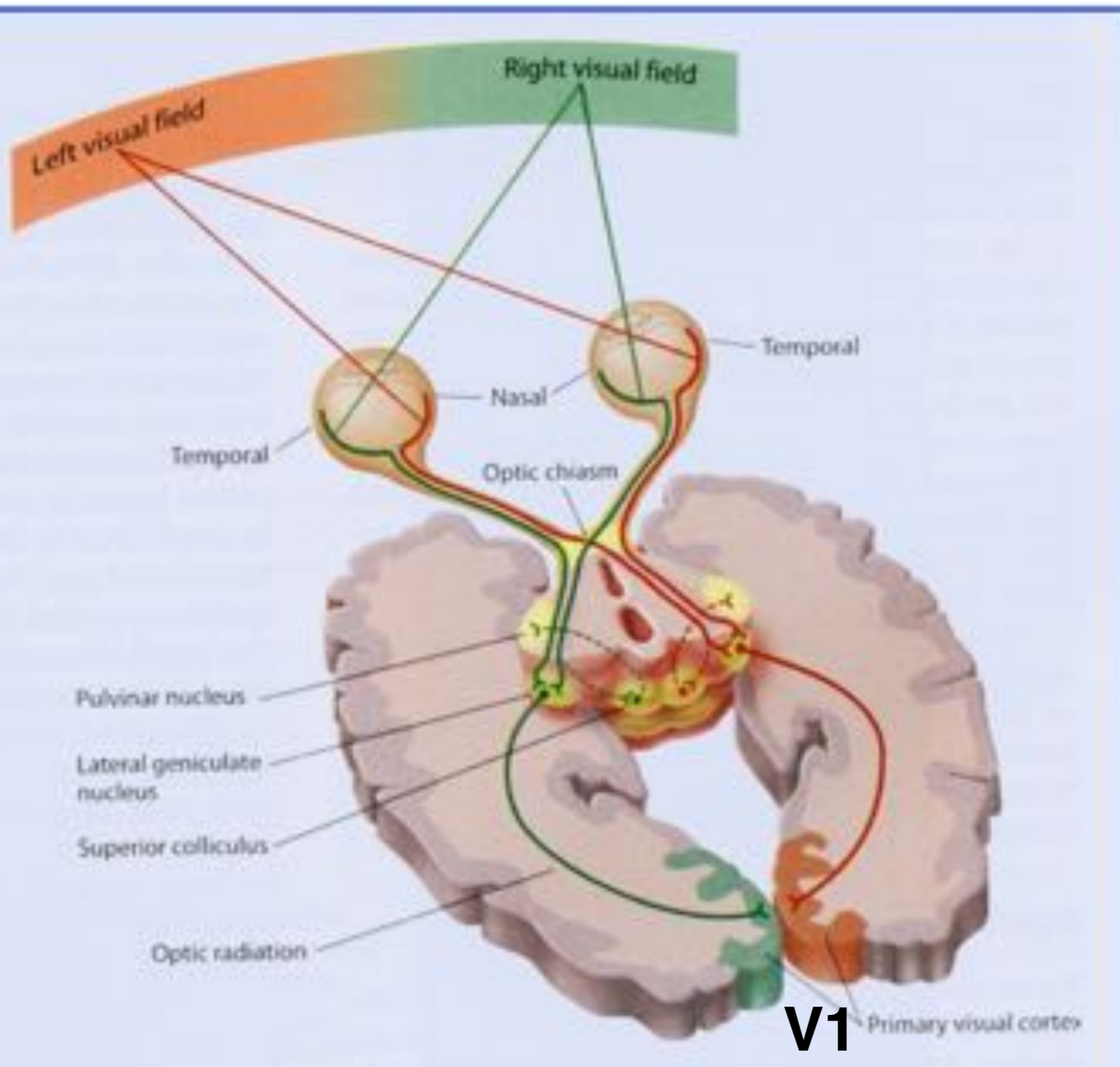

The Flow of Information

Lateral view

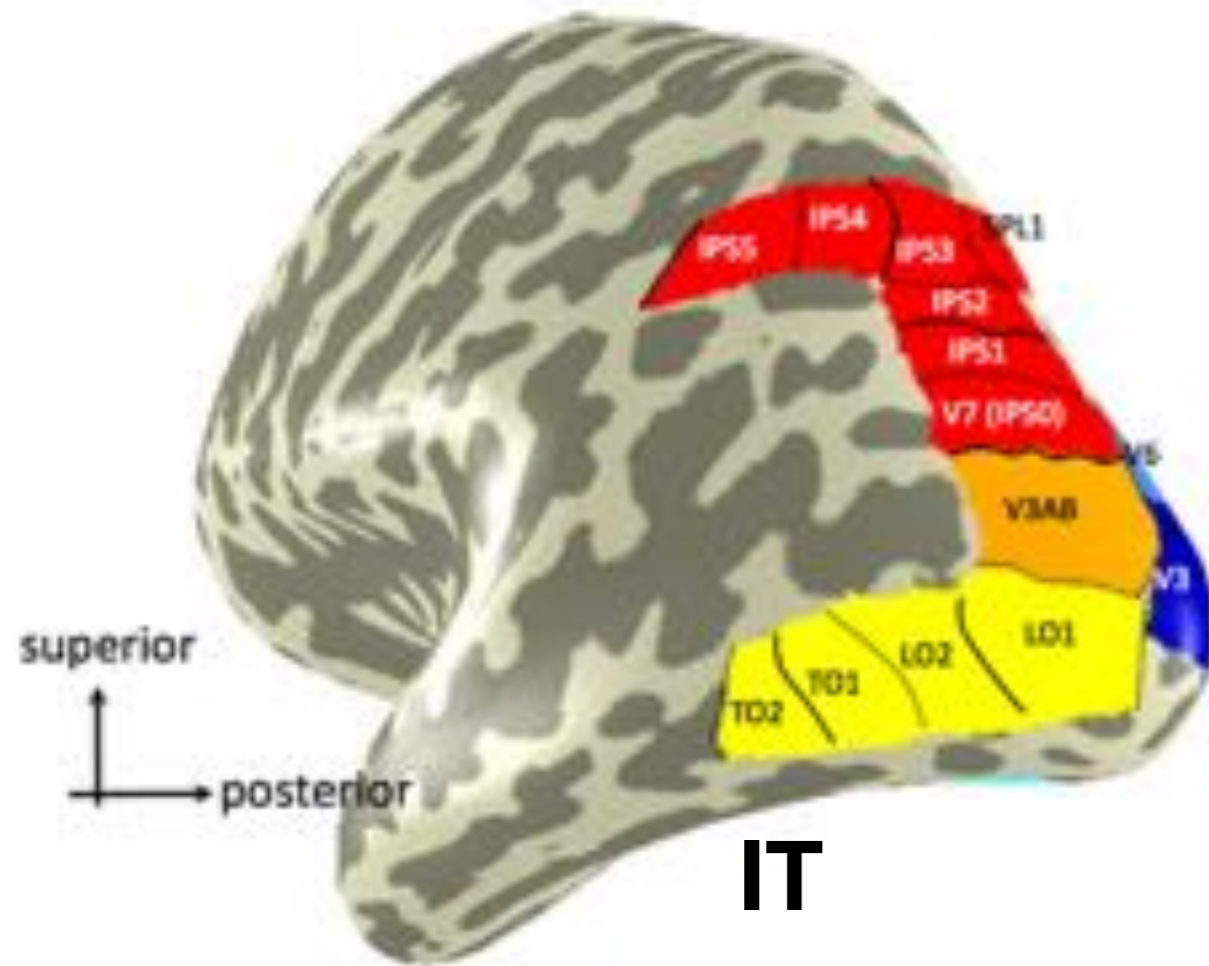

IT

Medial view

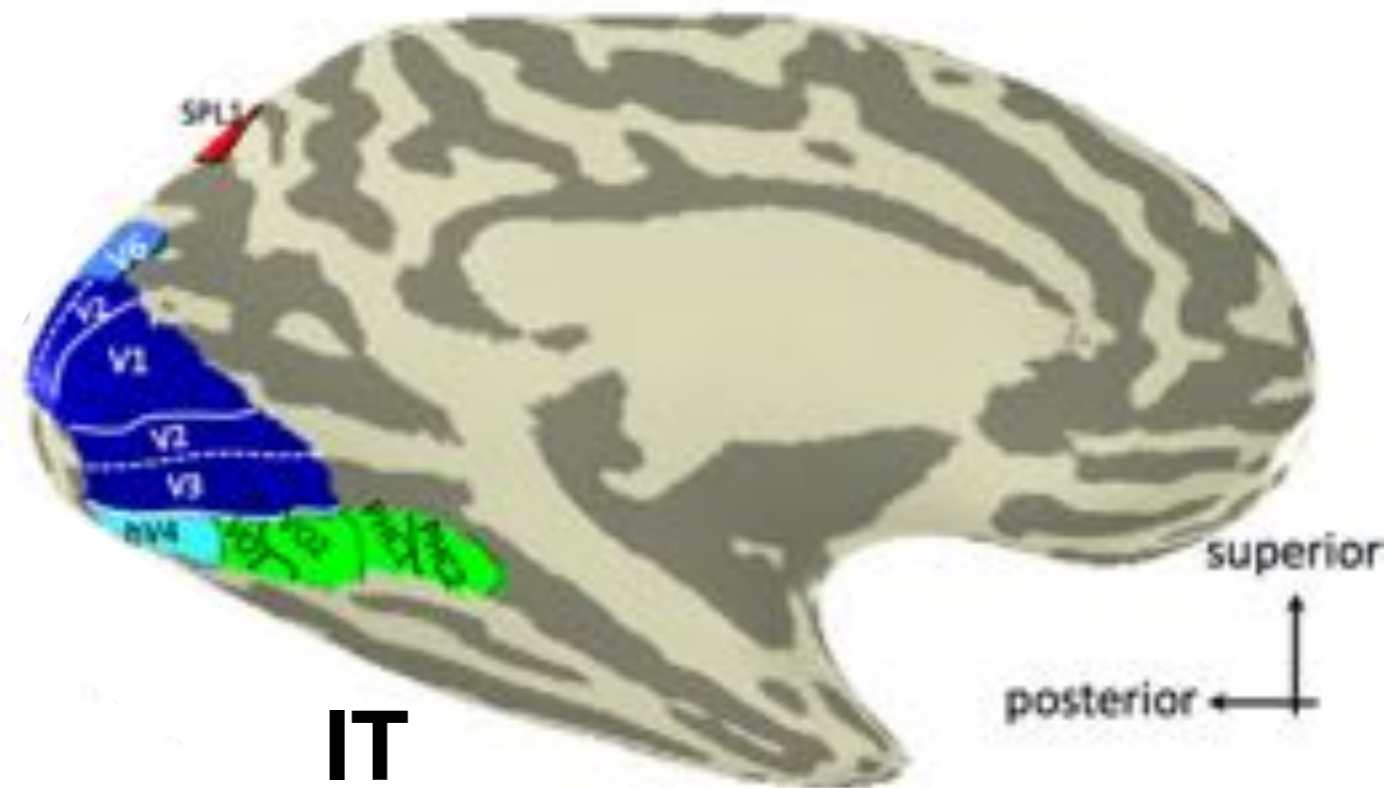

IT

■ Medial Occipital ■ Ventral Occipitotemporal ■ Lateral Occipitotemporal ■ Parietal

Weiner & Grill-Spector (2012)

Specialization: “What” and “Where” Pathways

monkey lesion studies

lesion “where” pathway: difficulty in spatial reasoning

lesion “what” pathway: difficulty in object recognition

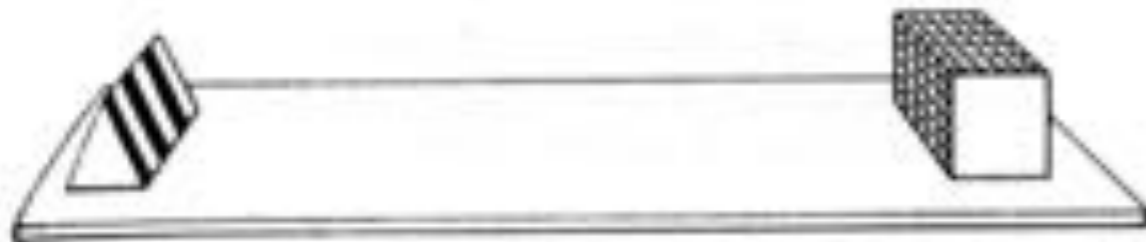

“what”



“where”

Mishkin & Ungerleider 1982

Specialization: “What” and “Where” Pathways

monkey lesion studies

lesion “where” pathway: difficulty in spatial reasoning

lesion “what” pathway: difficulty in object recognition

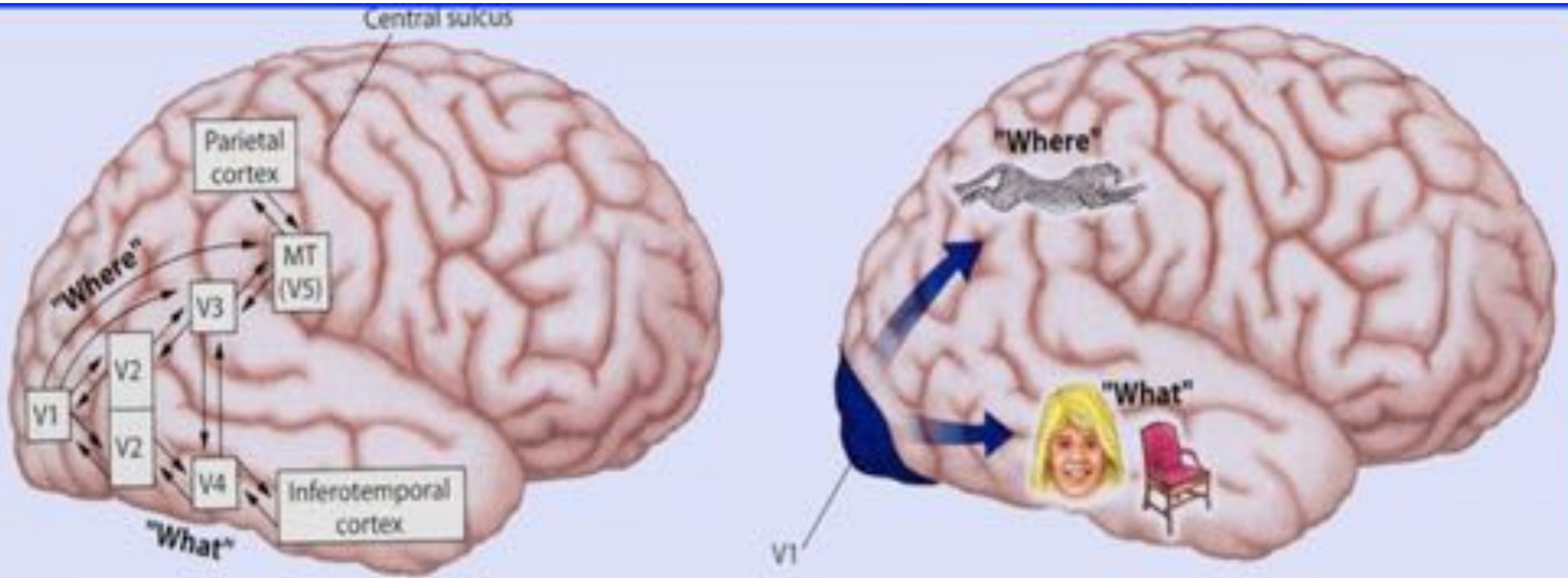

Mishkin & Ungerleider 1982

Object Recognition: The “What” Pathway

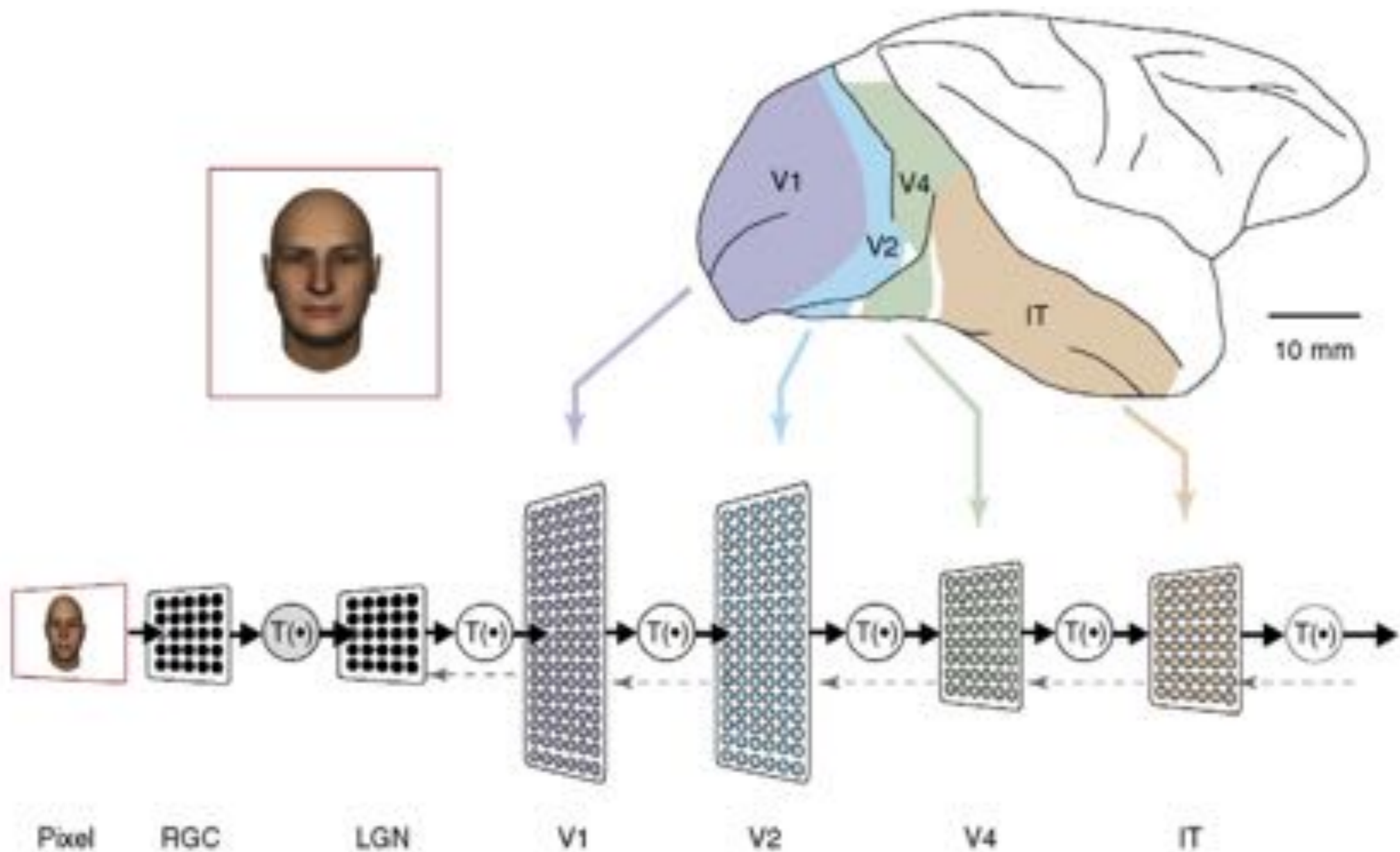

DiCarlo & Cox (2007)

Object Recognition: The “What” Pathway

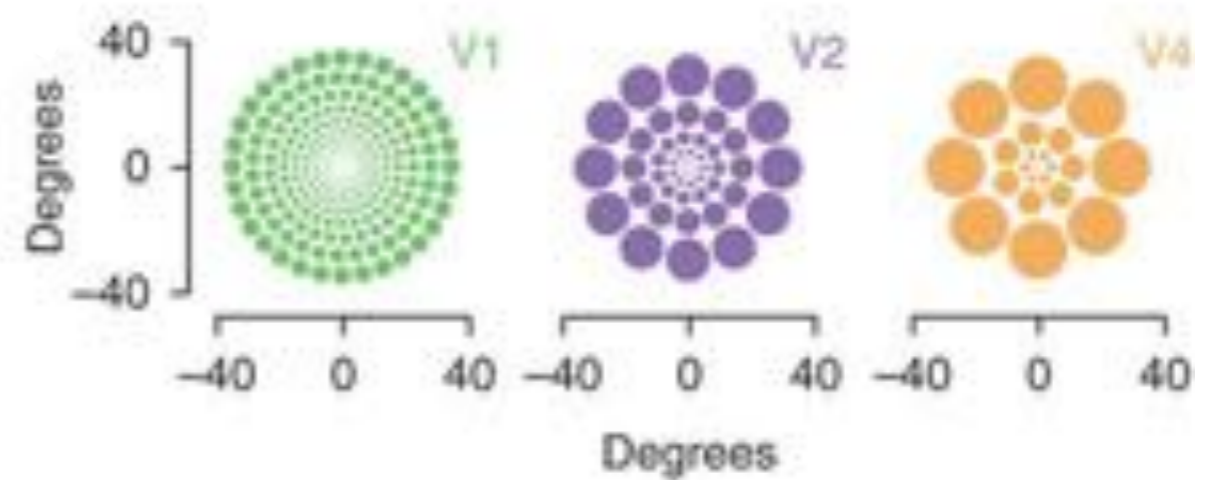
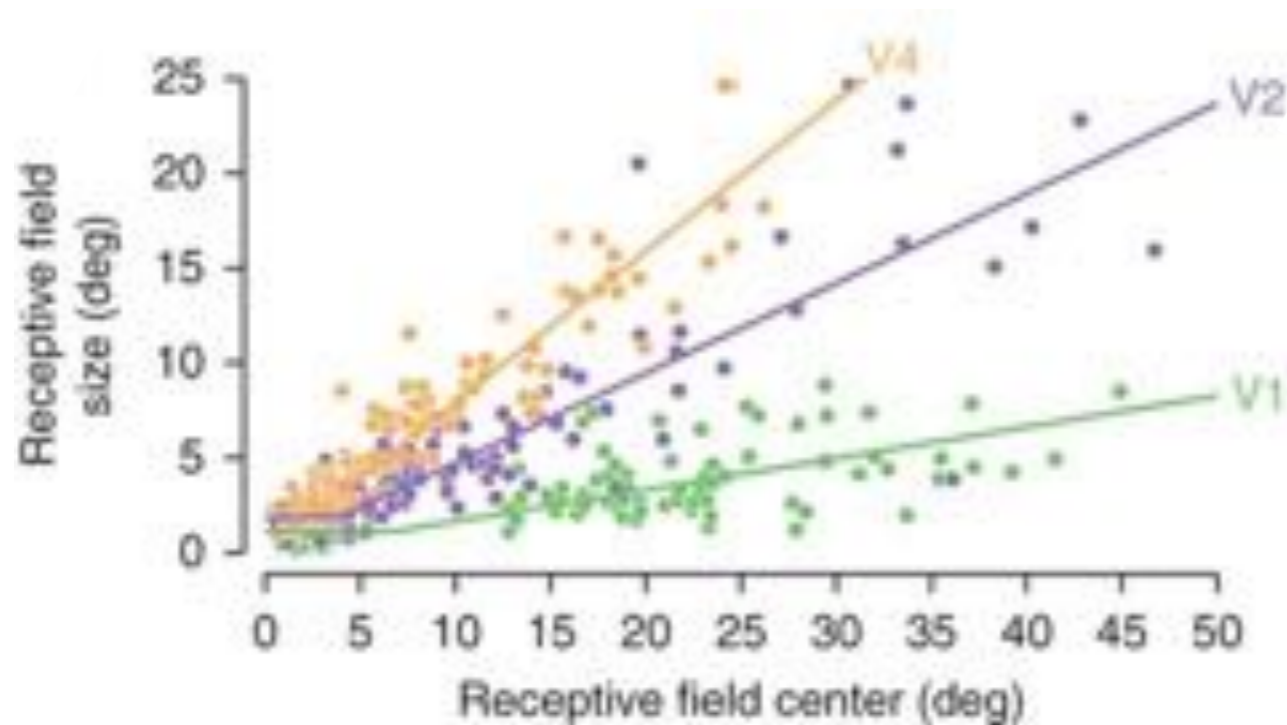

V1

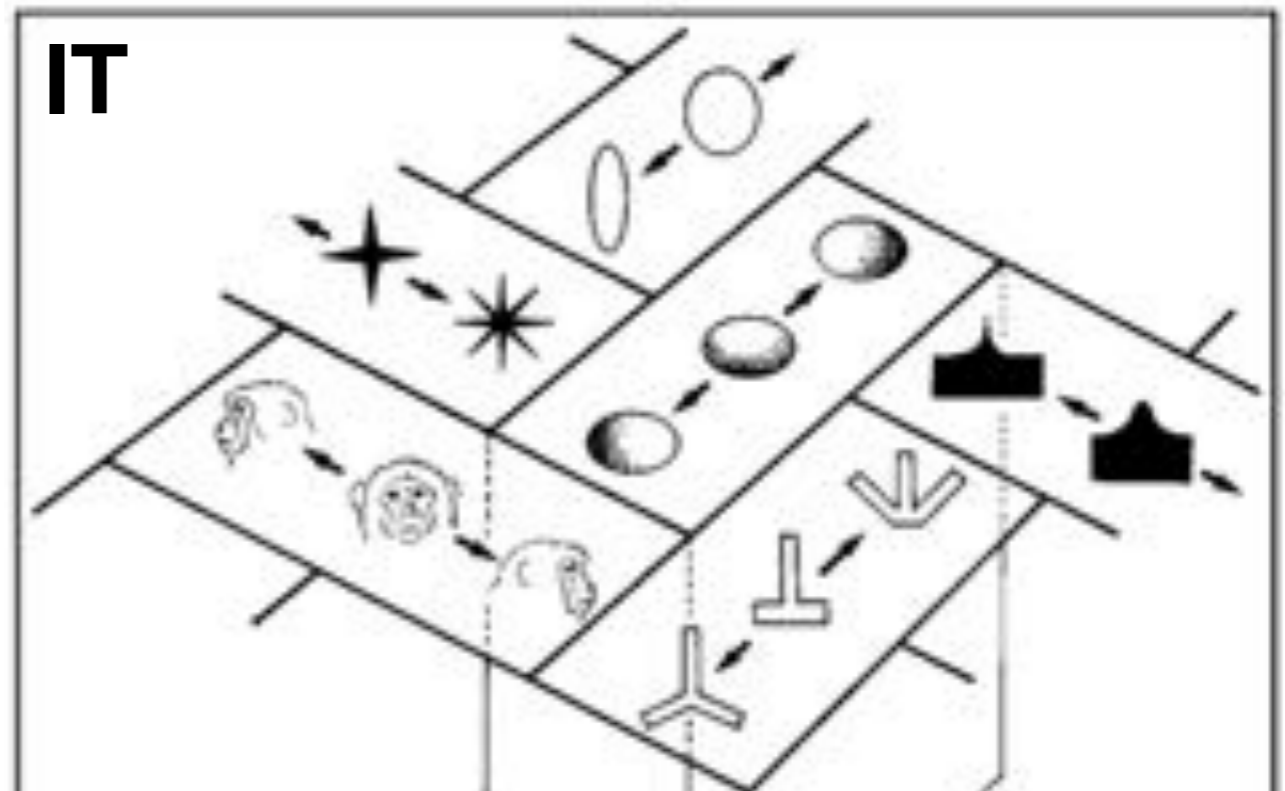
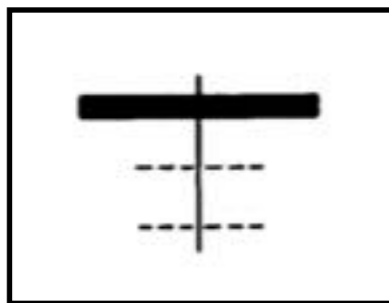

Freeman & Simoncelli (2011), Tanaka (1997)

Object Recognition: Building Features and Invariance

visual processing is done in stages

each area performs a transformation on its inputs

invariance is built gradually across many successive steps

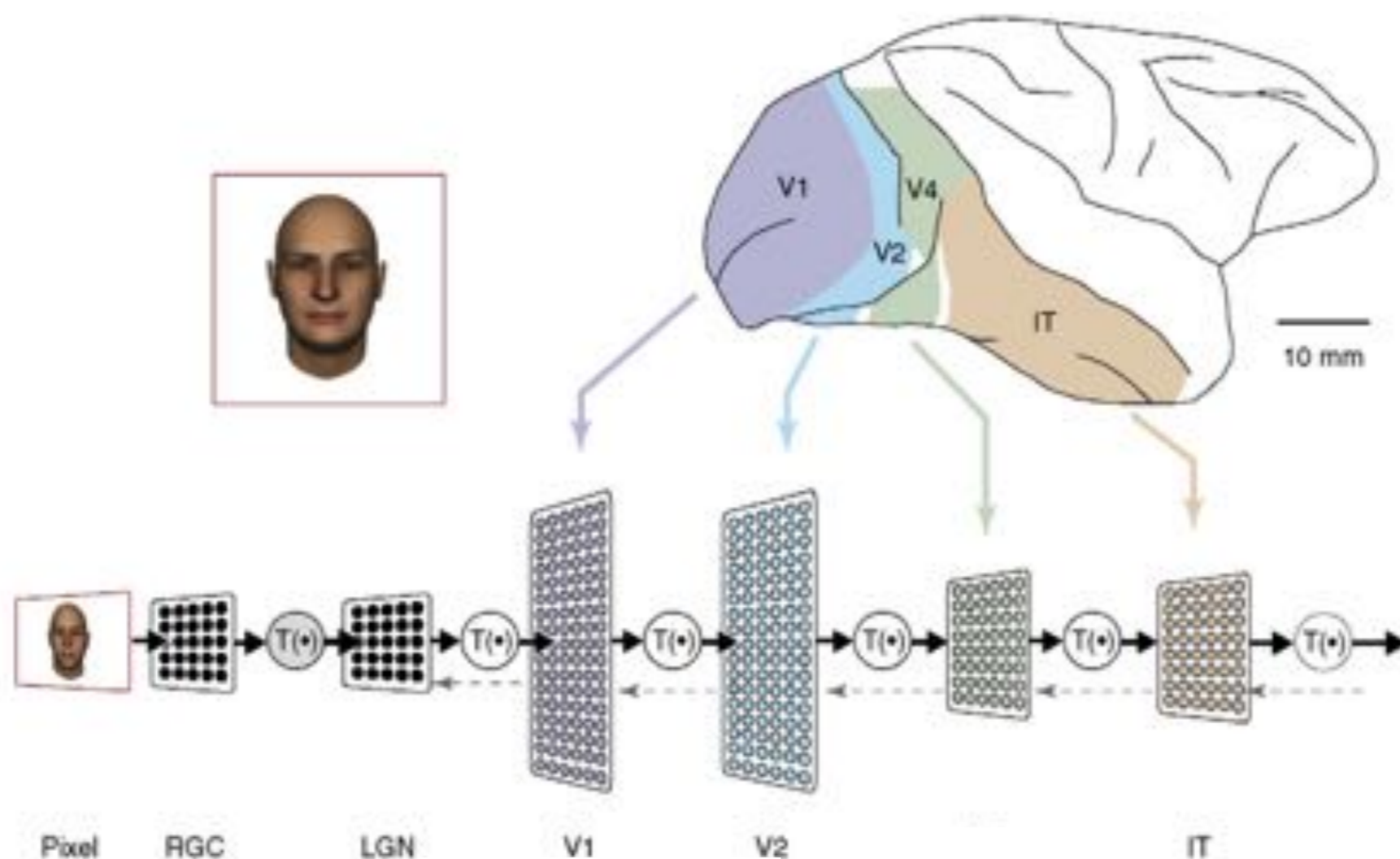

DiCarlo & Cox (2007)

2. Hierarchical Pattern Recognition Systems

neuroscience-inspired computer vision

Neocognitron: Neural Network

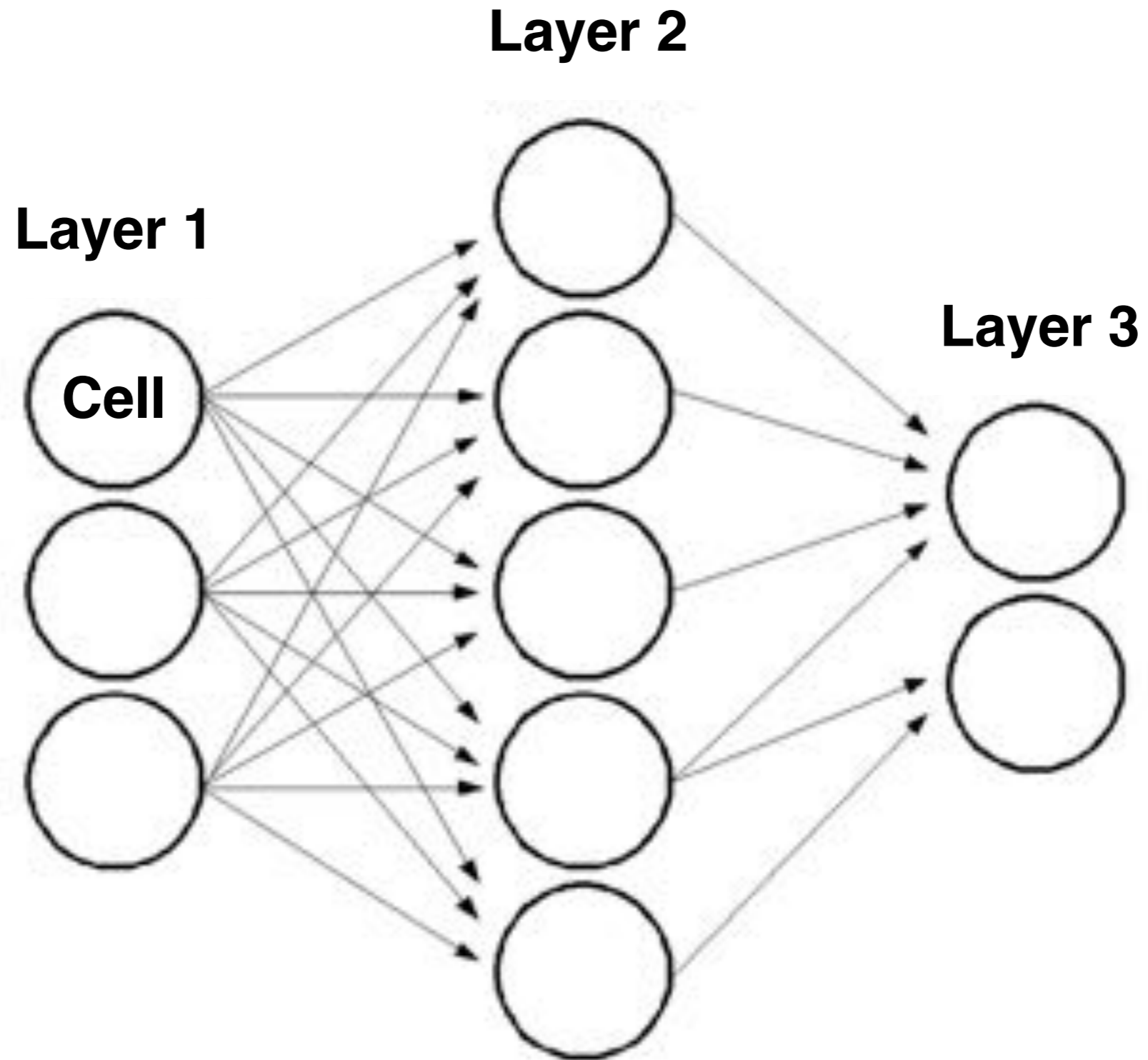

Neocognitron: Neural Network

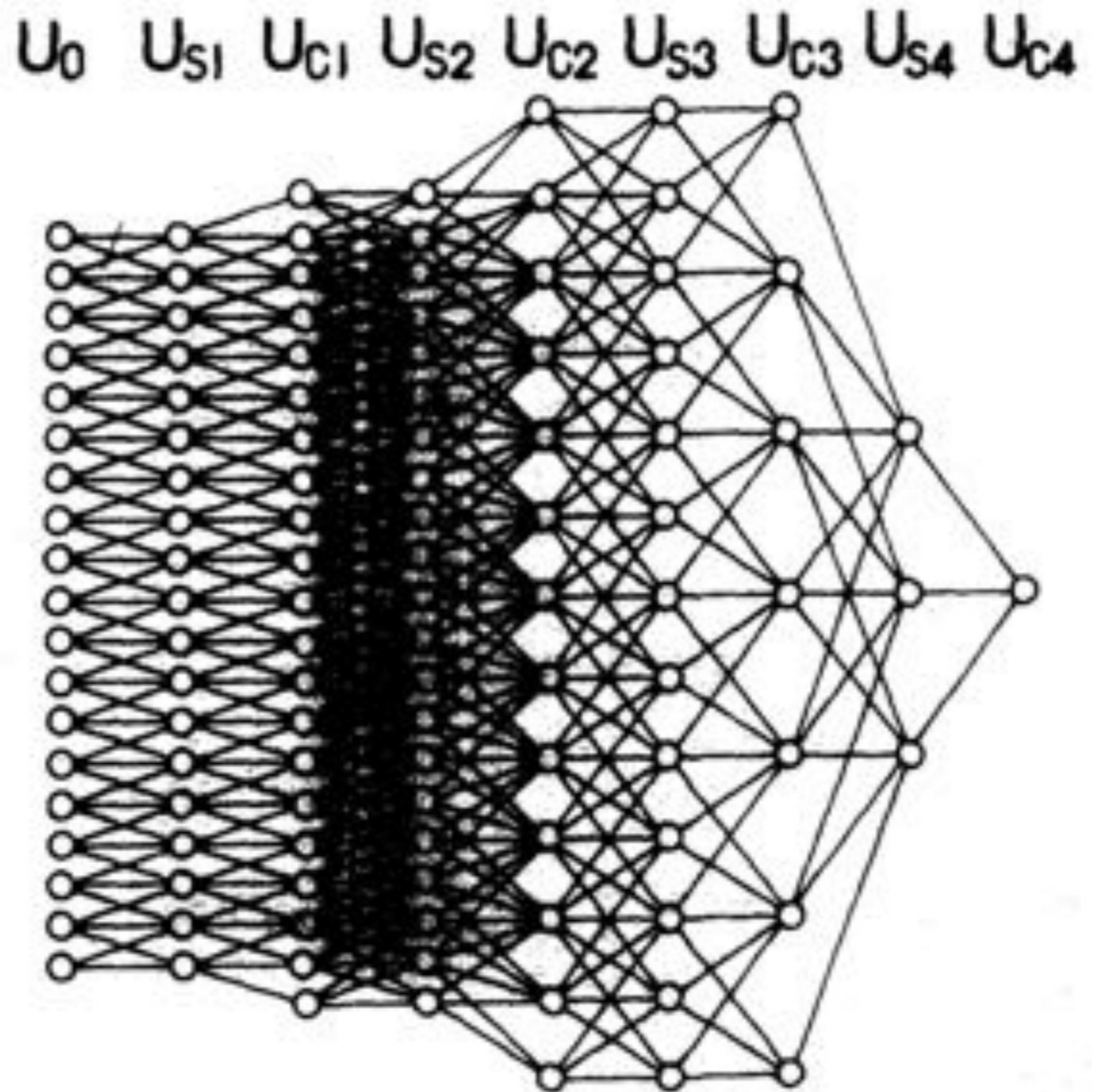

Fukushima (1988)

Neocognitron: Neural Network

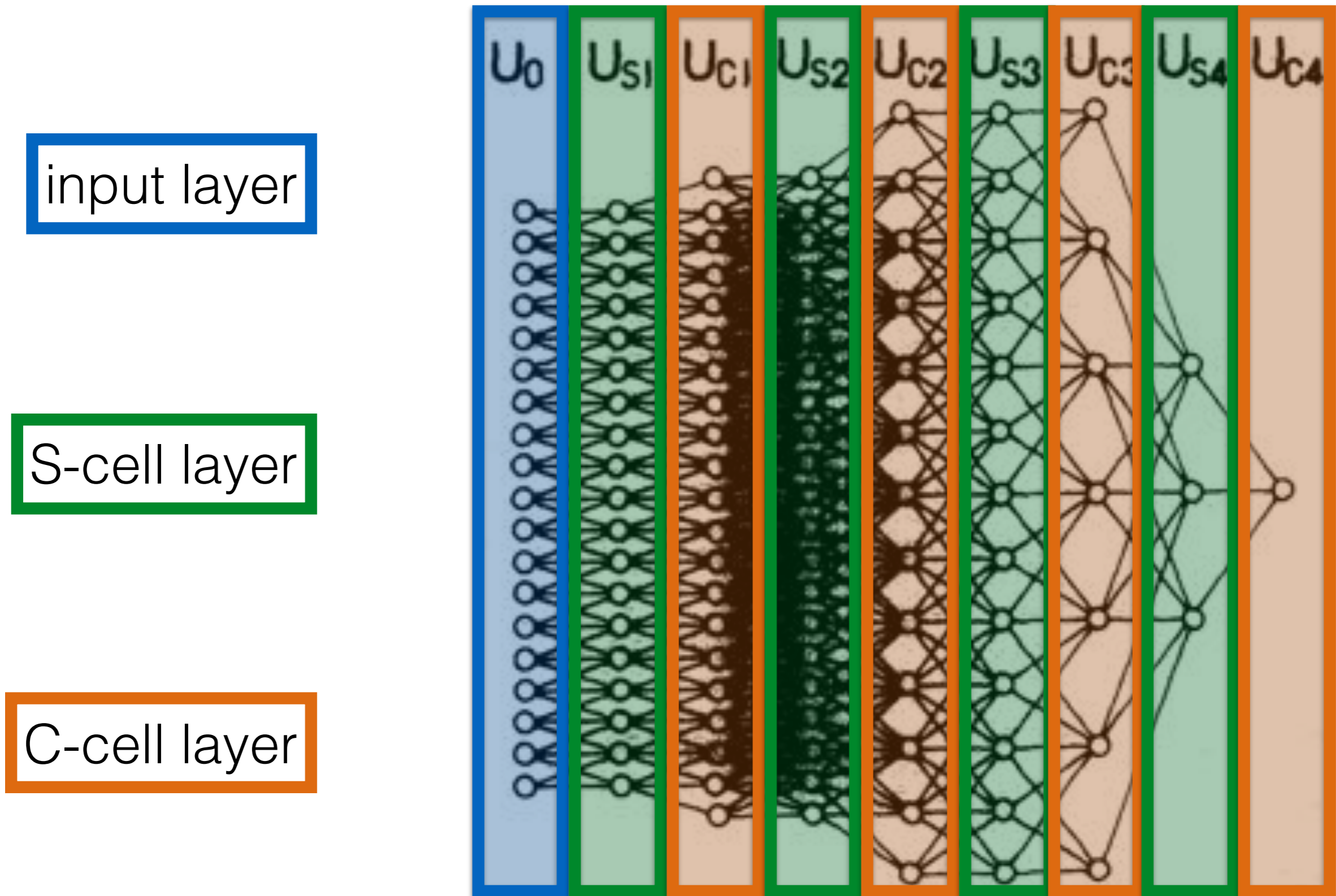

Fukushima (1988)

Neocognitron: S-Cell

C-cell layer /
input layer

S-cell layer

C-cell layer

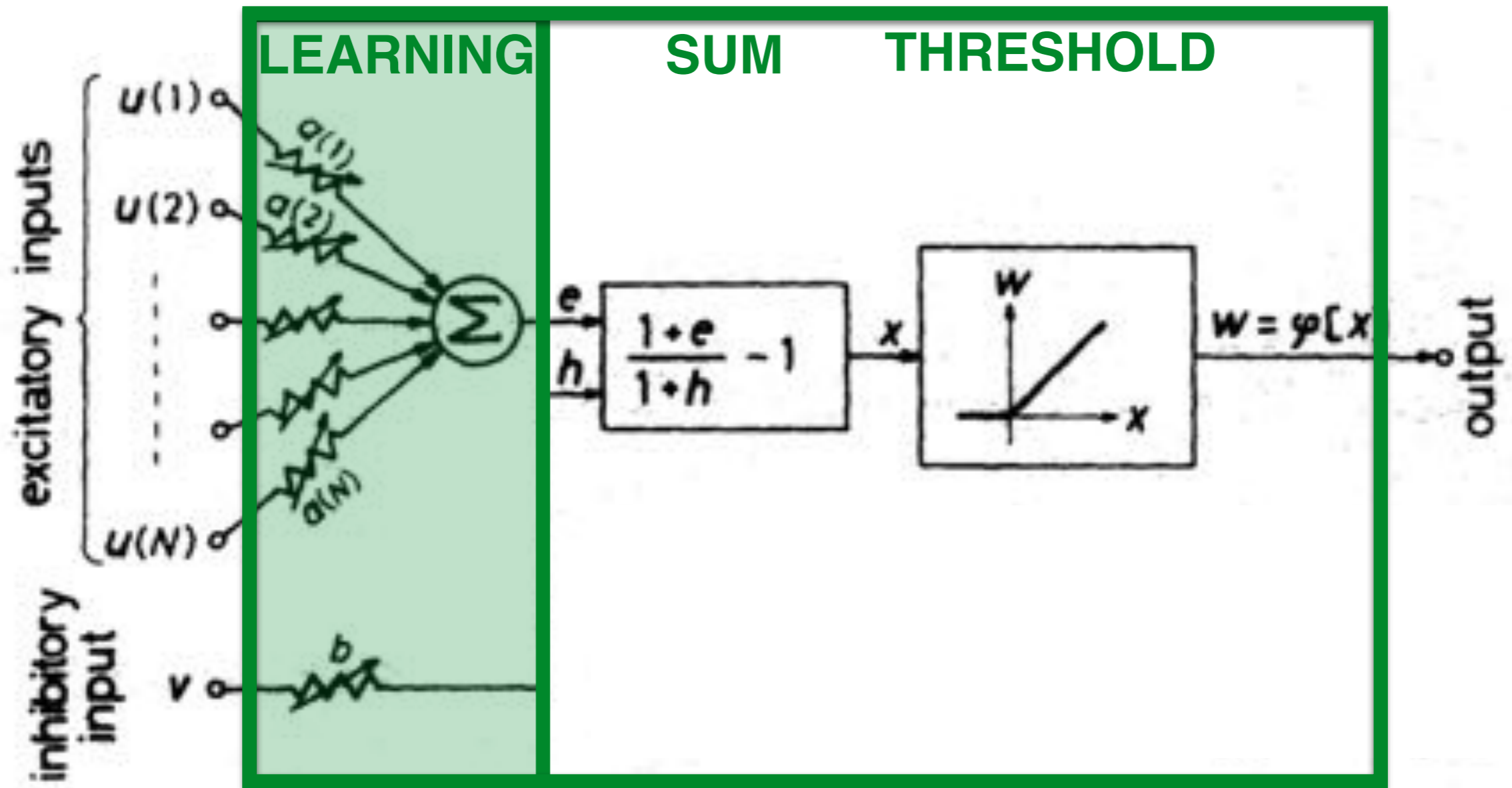

Fukushima (1988)

Neocognitron: S-Cell

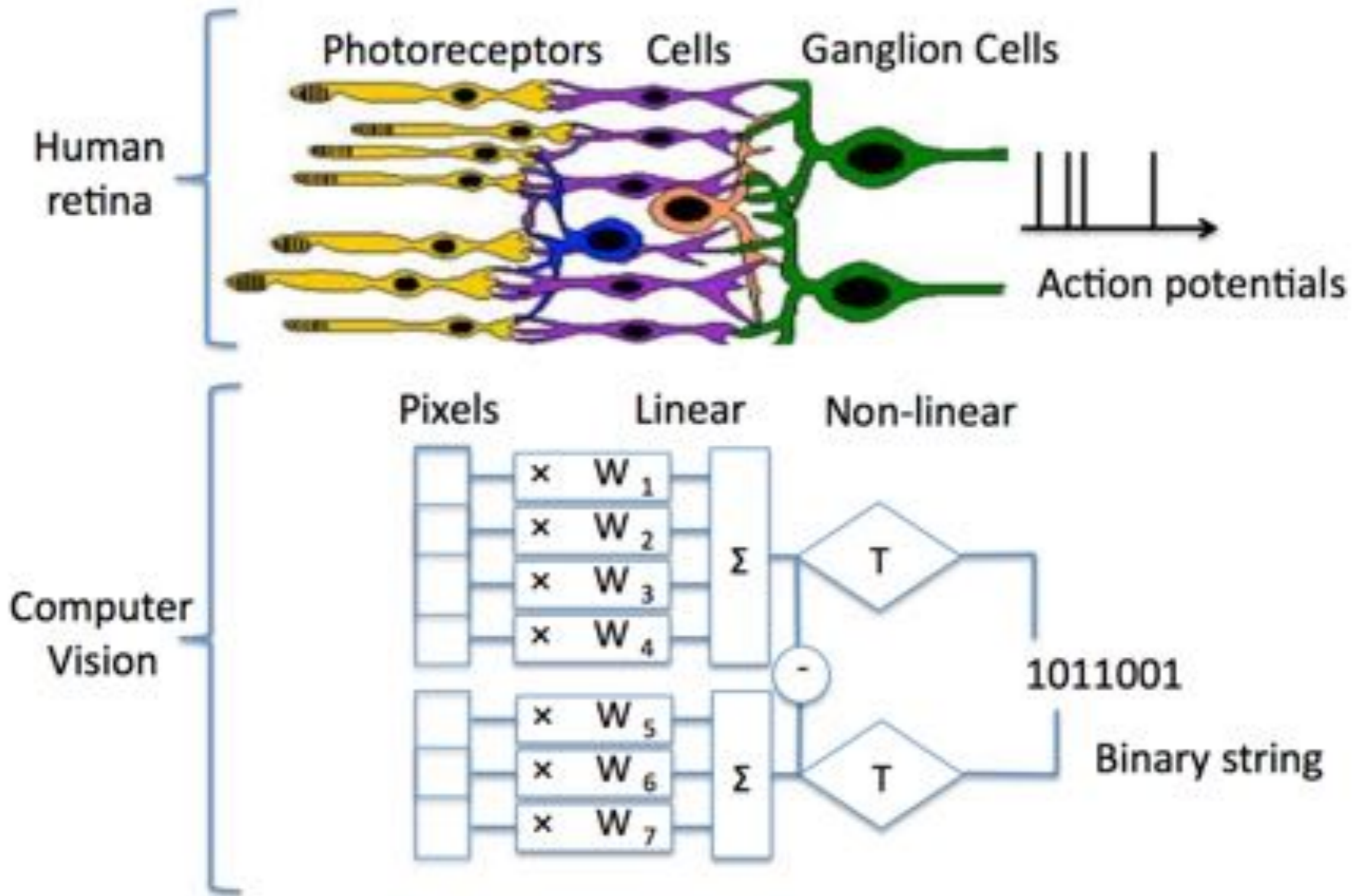
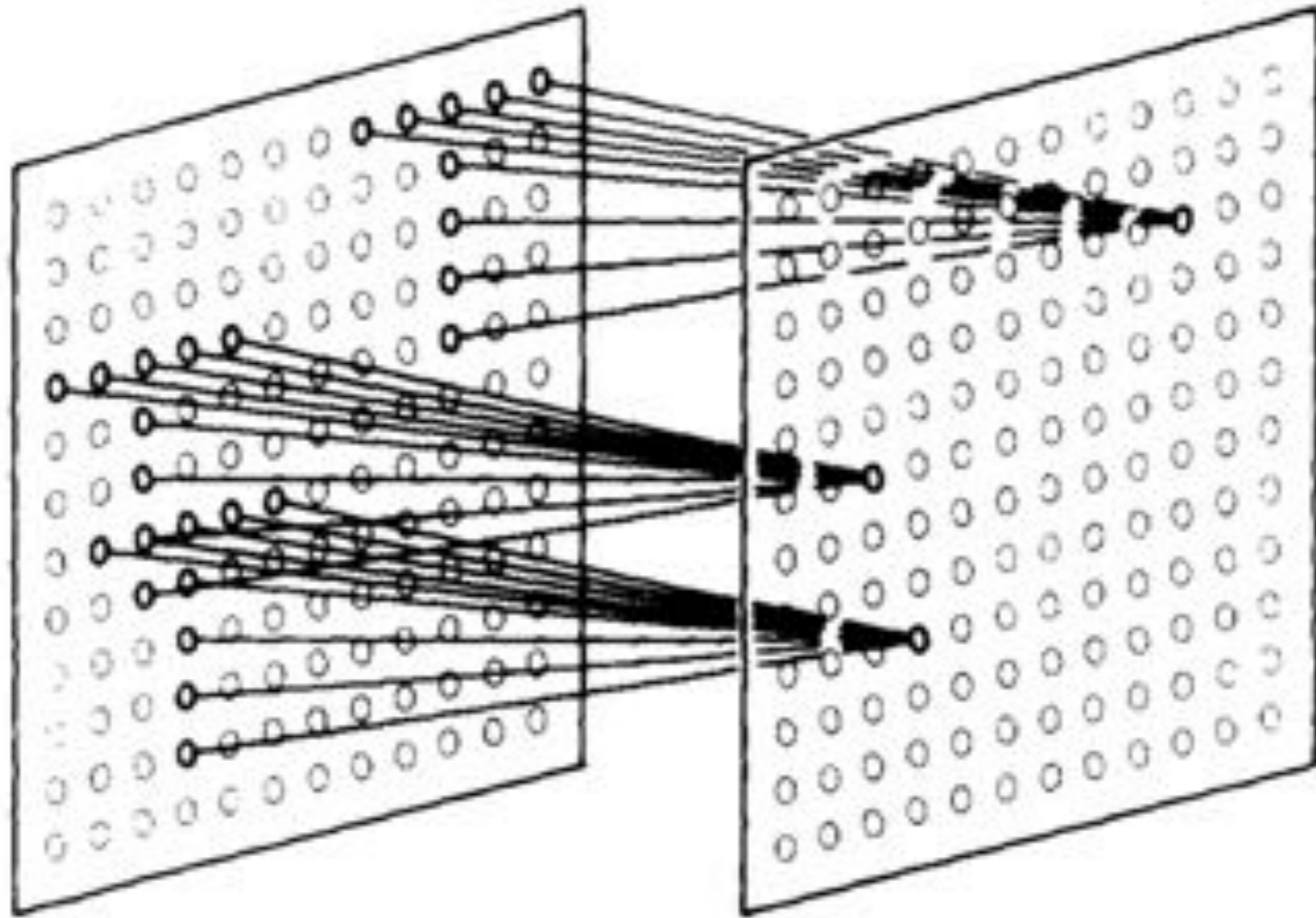

figure courtesy of A. Alahi

Neocognitron: C-Cell “Pooling”

building position invariance



Fukushima (1988)

Neocognitron: Network

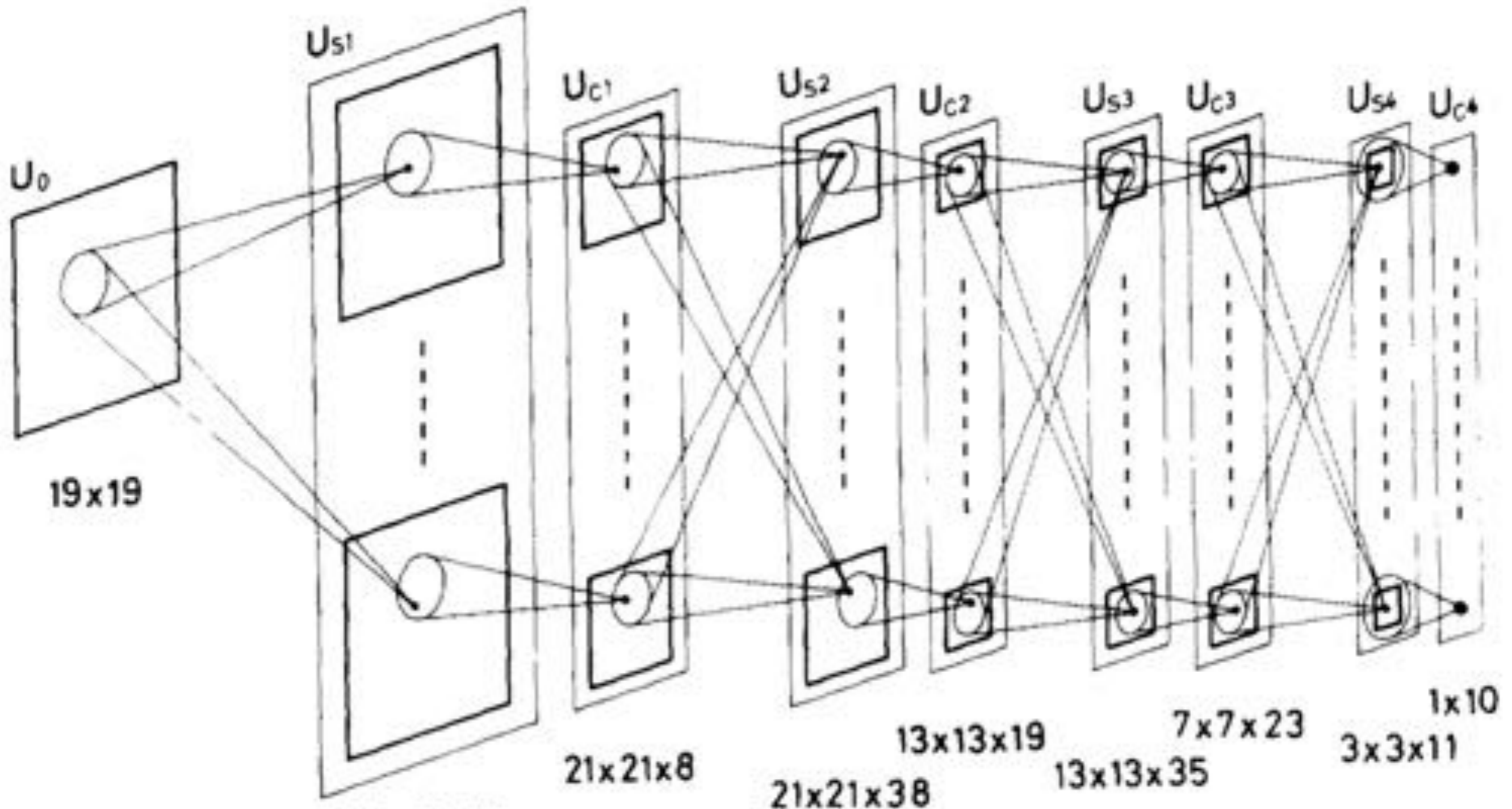

input S-cell C-cell S-cell C-cell S-cell C-cell S-cell C-cell

Fukushima (1988)

Neocognitron: Network

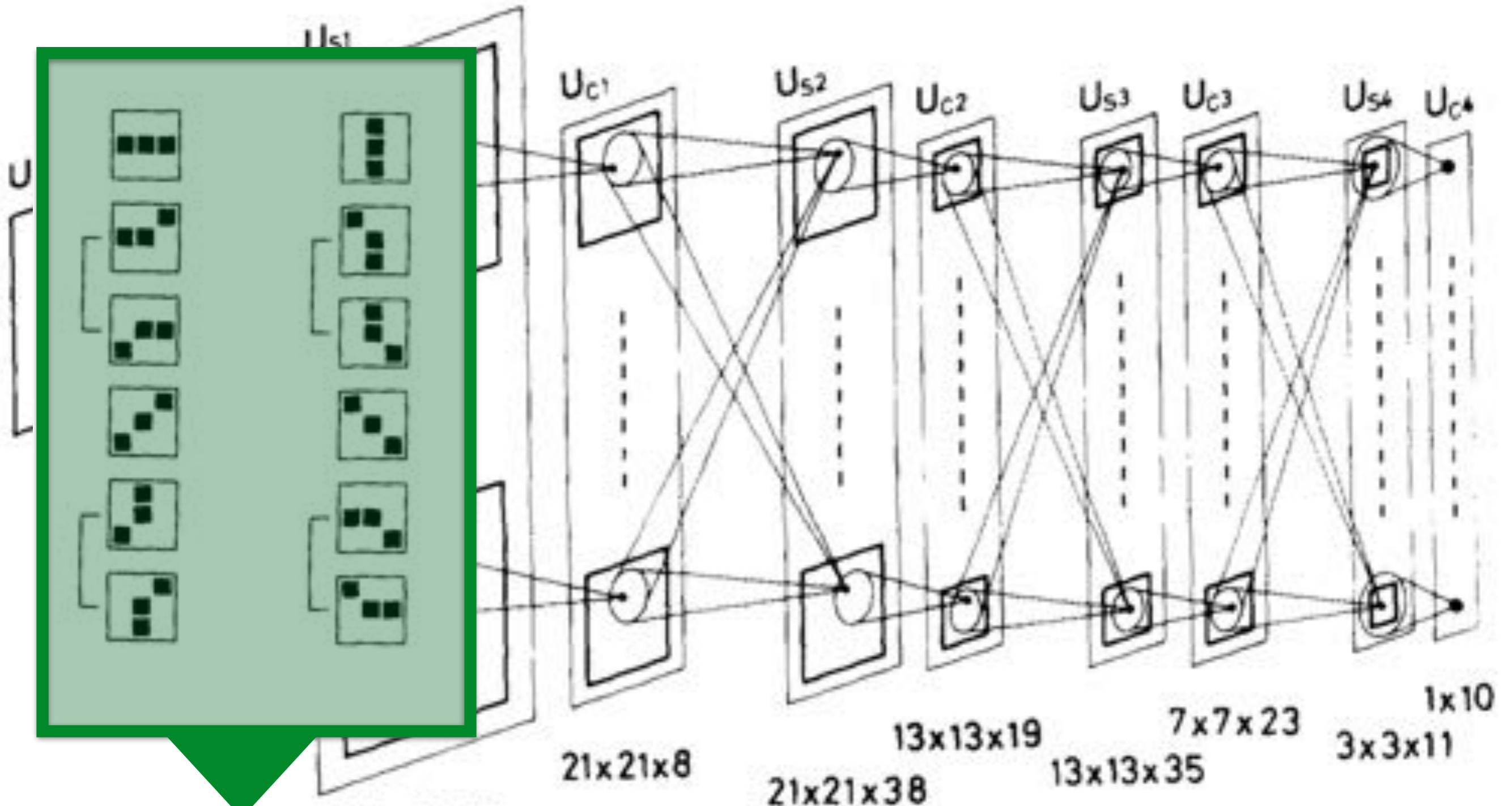

input S-cell C-cell S-cell C-cell S-cell C-cell S-cell C-cell

Fukushima (1988)

Neocognitron: Network

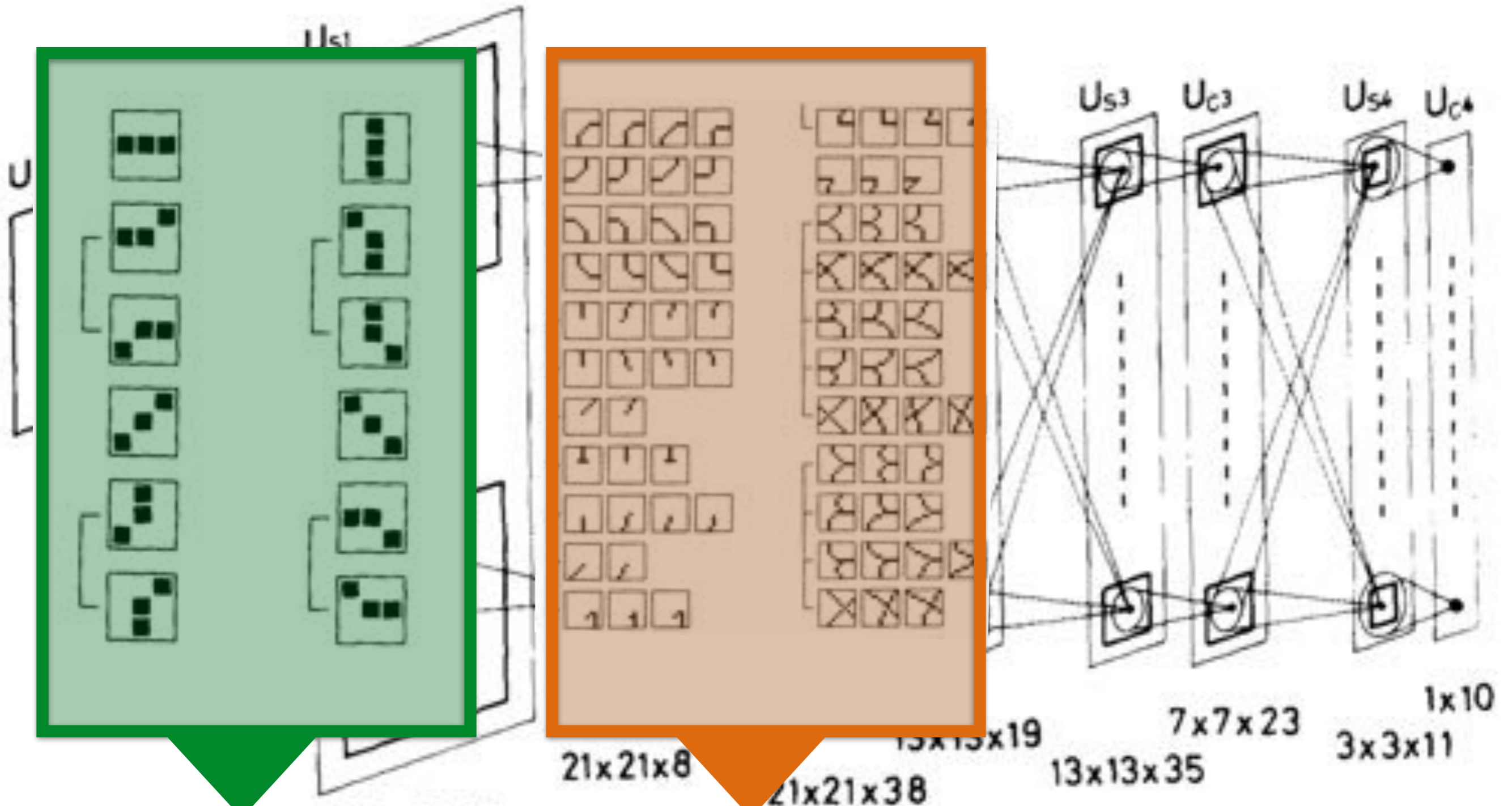

input S-cell C-cell S-cell C-cell S-cell C-cell S-cell C-cell

Fukushima (1988)

Neocognitron: Network

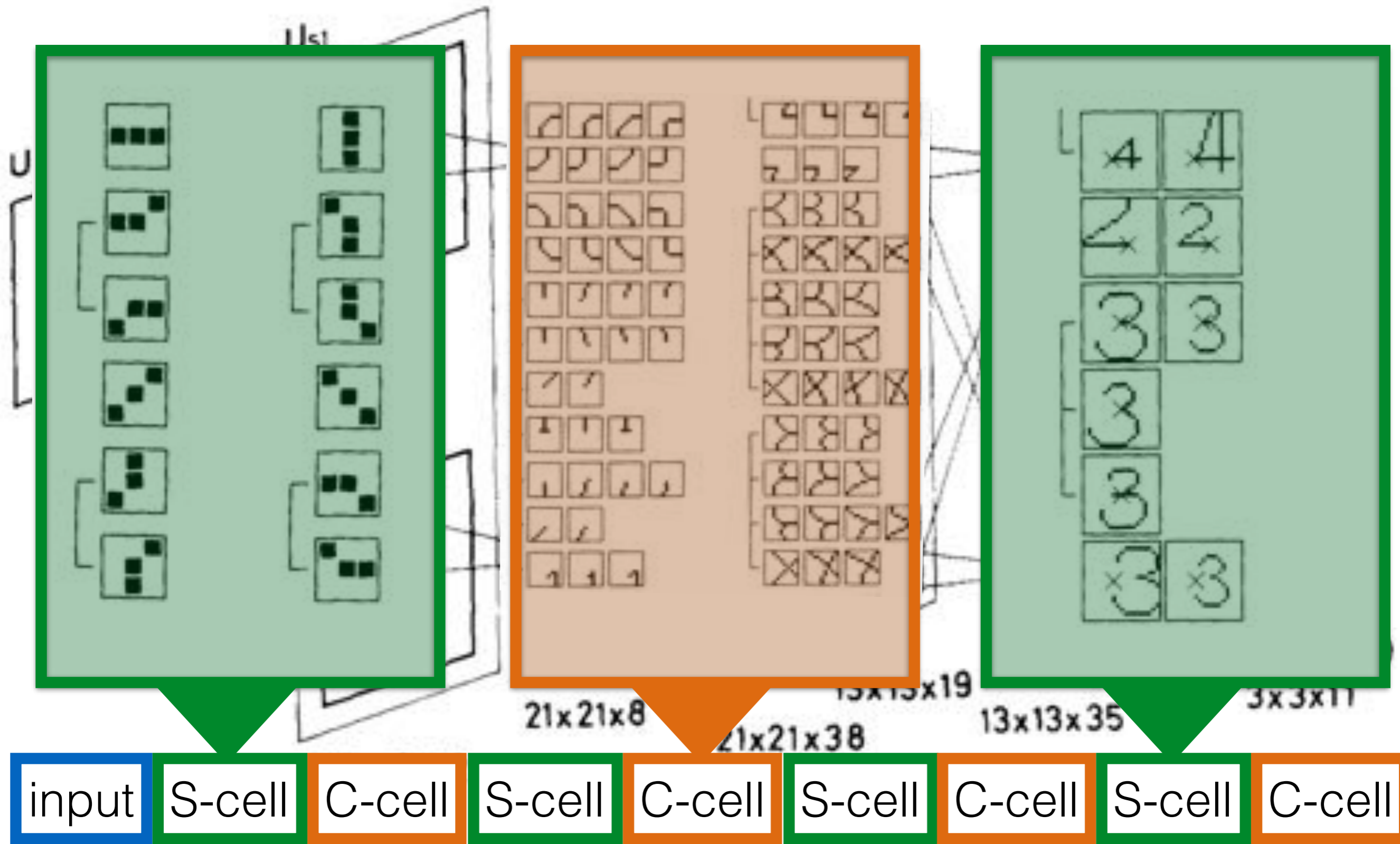

Fukushima (1988)

Neocognitron: Robust Results

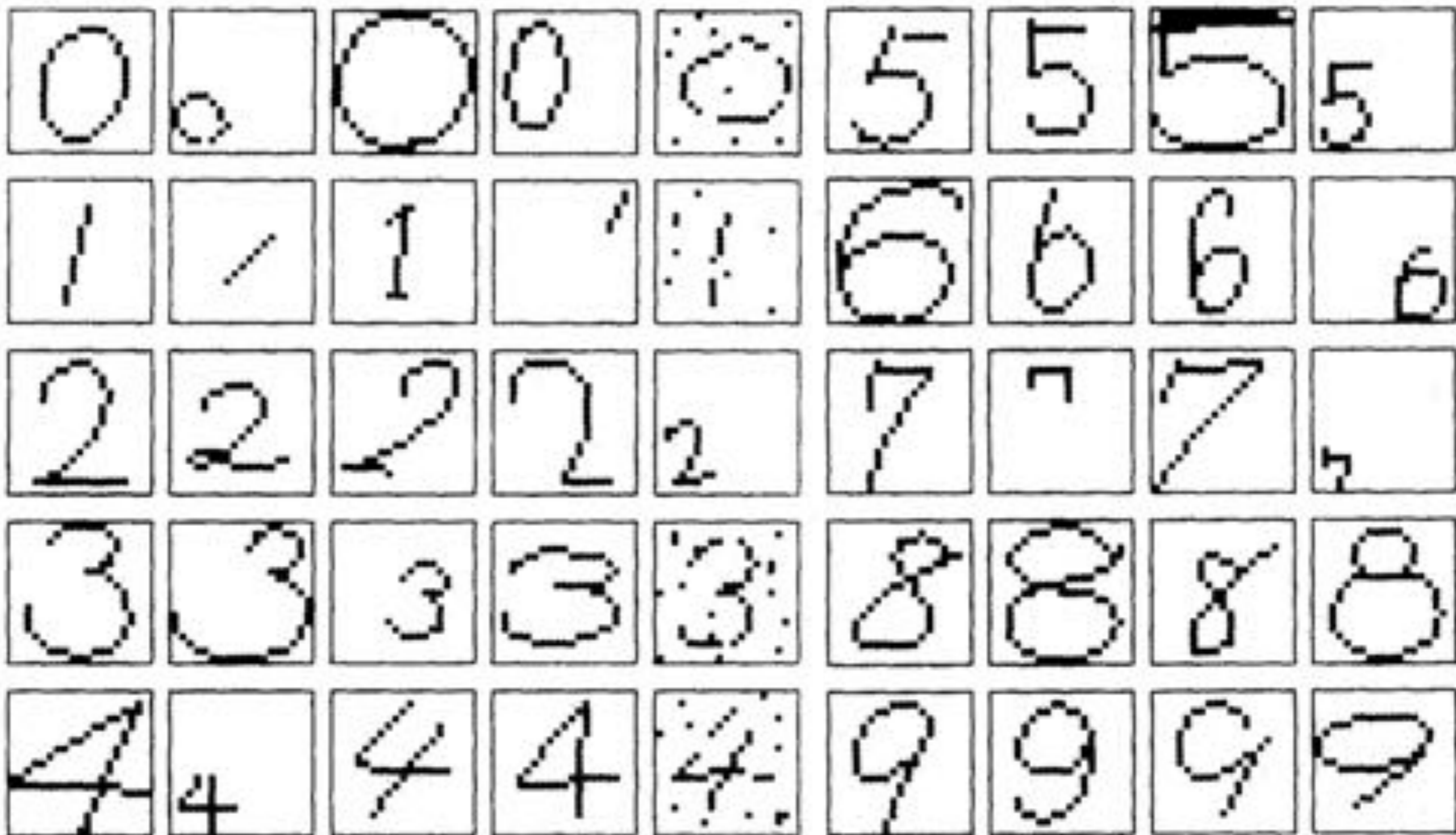

Fukushima (1988)

Neocognitron

biologically inspired hierarchical processing pipeline
invariance is built gradually across many successive steps
simple neural network solves complicated non-linear problem

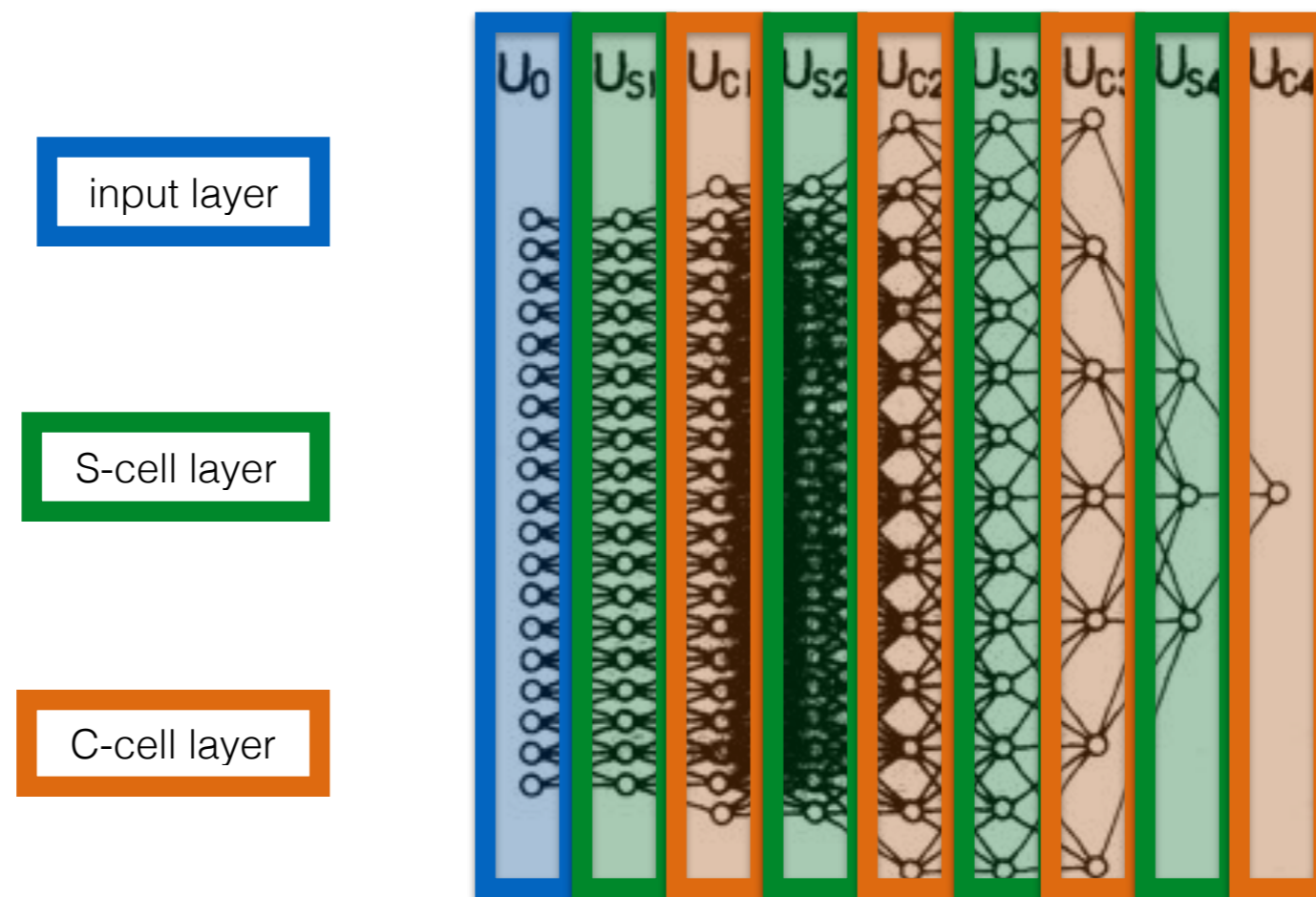

Fukushima (1988)

Feed-Forward Object Recognition Model

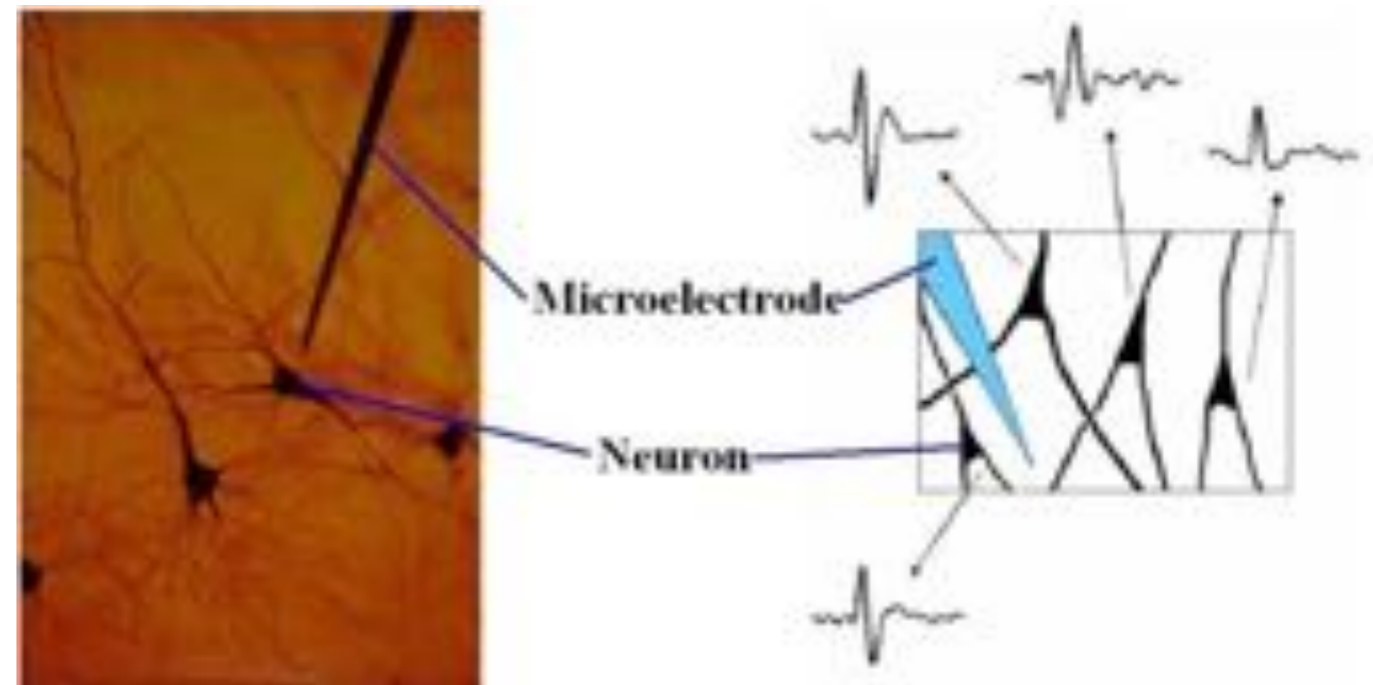
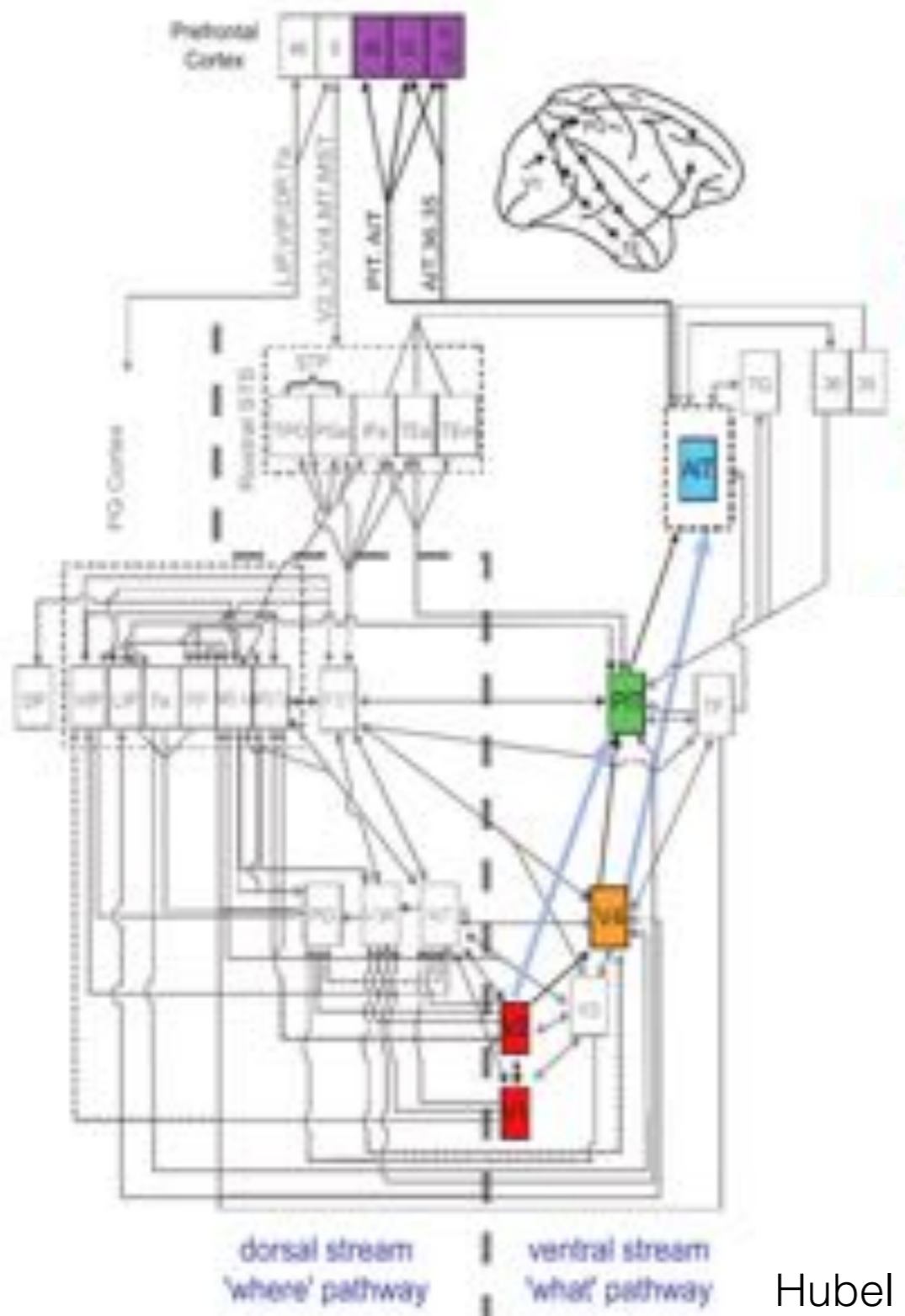

Hubel & Wiesel (1962), Riesenhuber & Poggio (1999), Serre et al. (2007)

Feed-Forward Object Recognition Model

task: is there an animal in the picture?

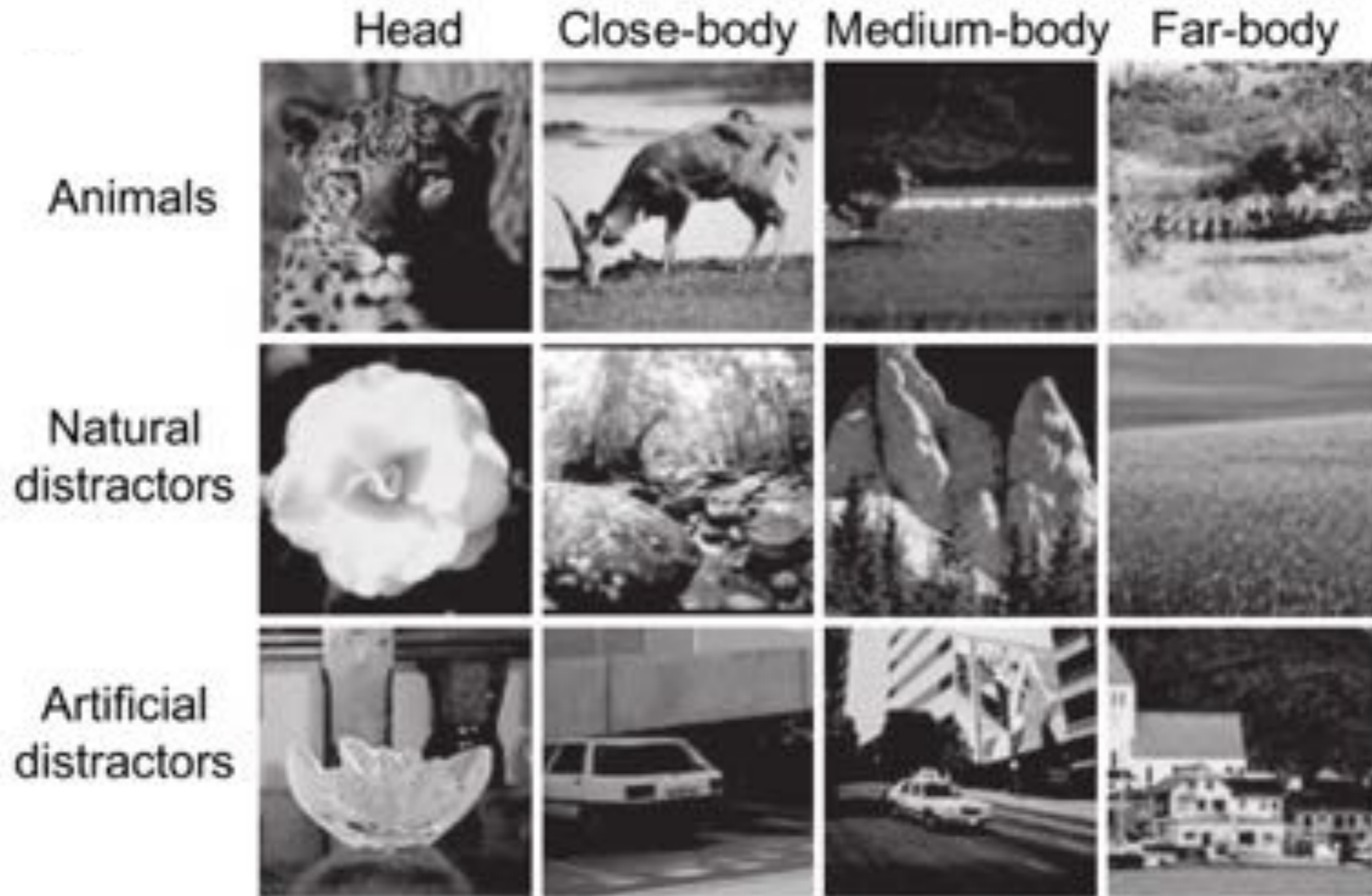

Serre et al. (2007)

Feed-Forward Object Recognition Model

task: is there an animal in the picture?

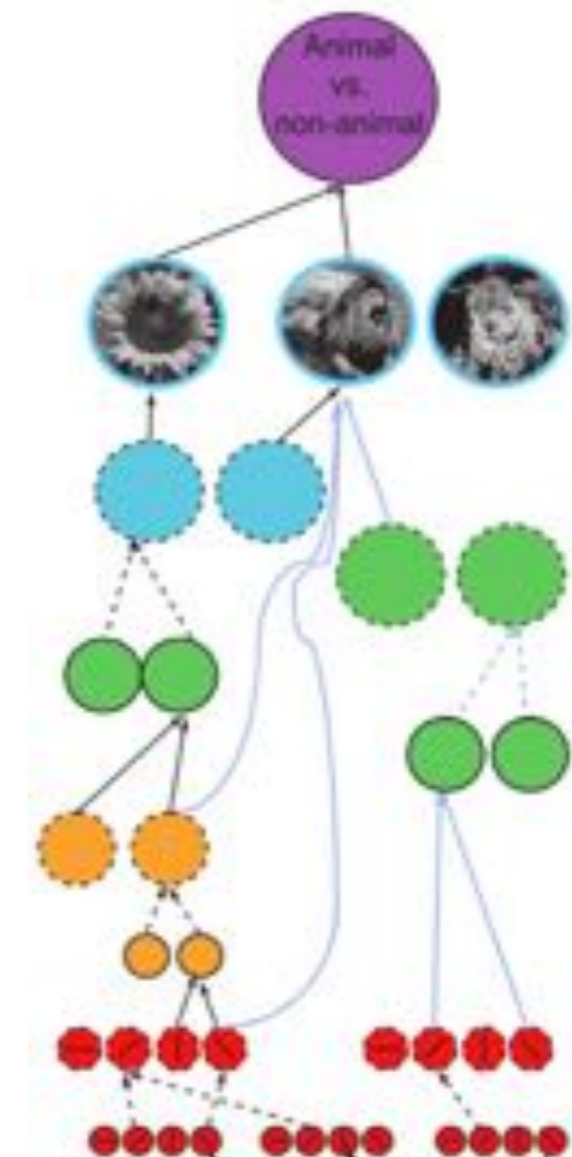
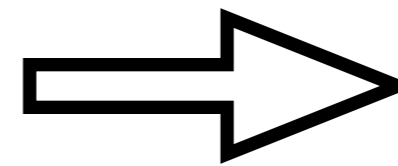

Serre et al. (2007)

Feed-Forward Object Recognition Model

task: is there an animal in the picture?

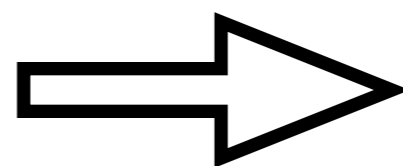

Serre et al. (2007)

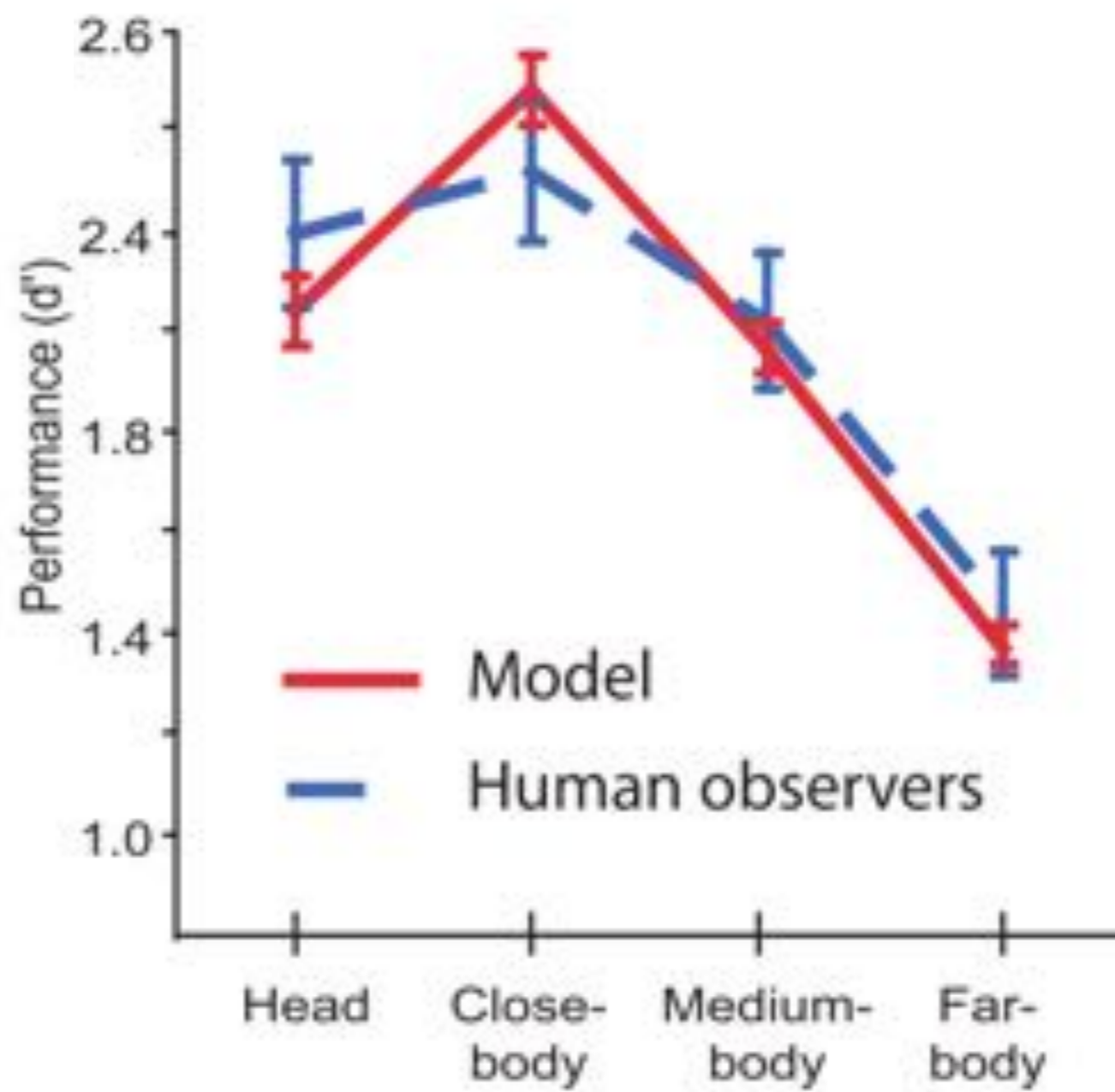

Feed-Forward Object Recognition Model

task: is there an animal in the picture?

Mod: 100% Hum: 96% Mod: 91% Hum: 83%



Mod: 20% Hum: 75% Mod: 100% Hum: 25%



Mod: 100% Hum: 96% Mod: 100% Hum: 91%



Mod: 10% Hum: 71% Mod: 100% Hum: 29%



Serre et al. (2007)

Feed-Forward Object Recognition Model

biologically-inspired processing pipeline

patches — receptive fields
building invariance
hierarchical processing

major drawback?

no feedback

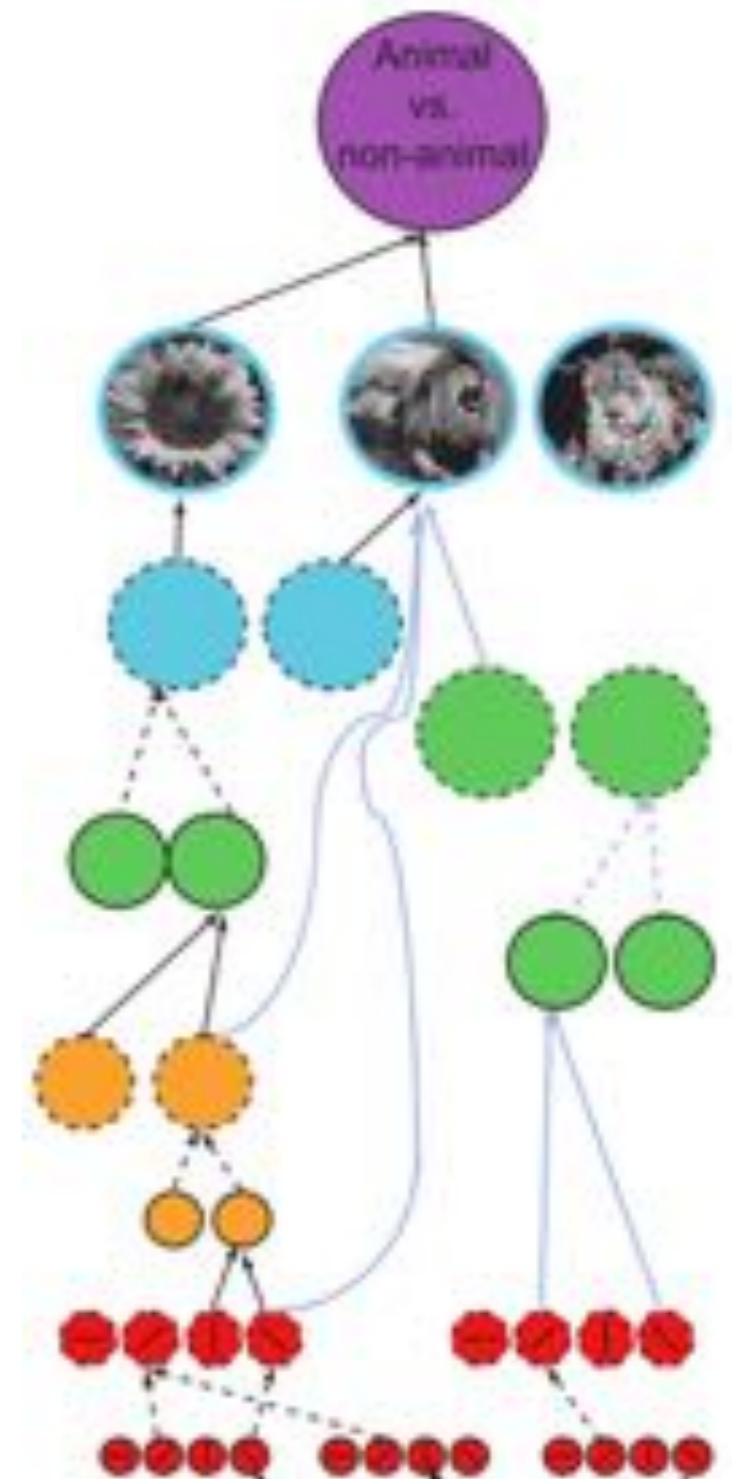

Serre et al. (2007)

Discussion

how closely should we aim to copy human vision?

is reverse-engineering human vision
a self-imposed limitation?

perfect recognition vs. visual understanding?

3. Modern Neural Networks

extremely large scale data and computation

Deep Convolutional Neural Network

650,000 cells — 60,000,000 parameters

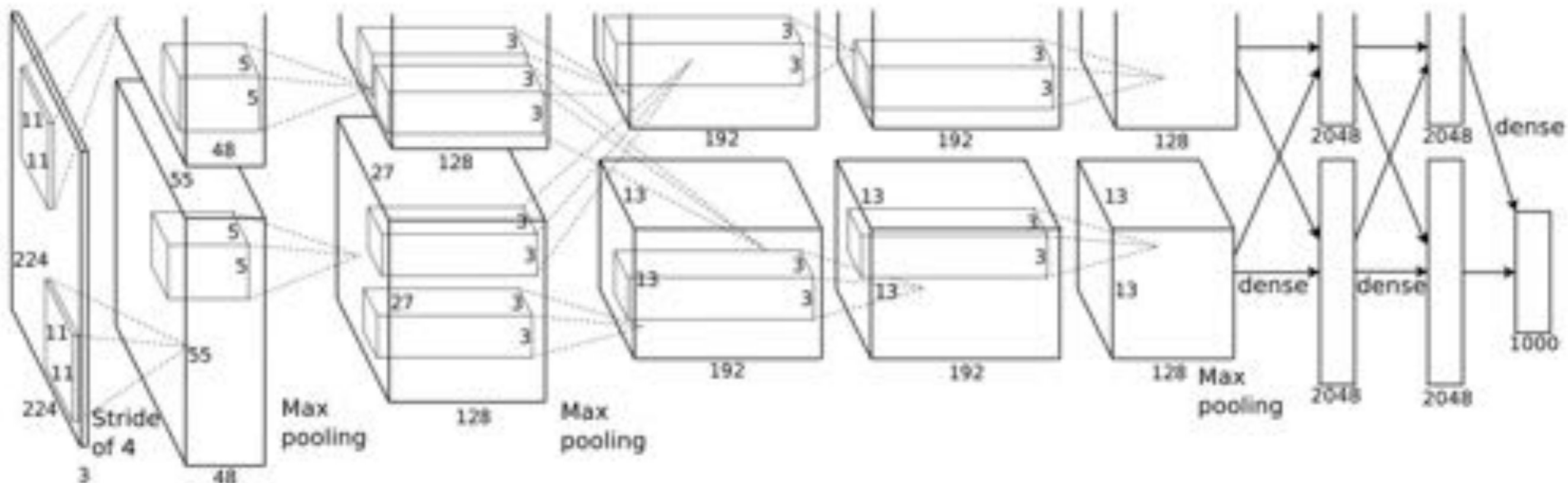

input convolution pooling ... convolution pooling fully-connected

Krizhevsky et al. (2013)

Deep Convolutional Neural Network

650,000 cells — 60,000,000 parameters

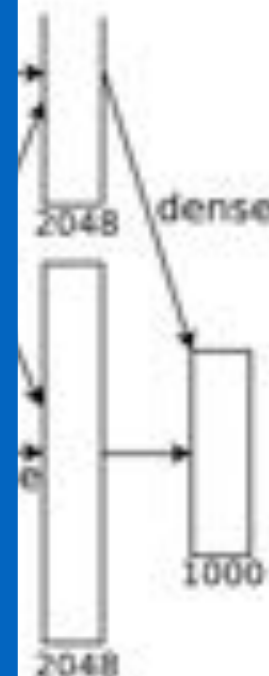

input convolution pooling ... convolution pooling fully-connected

Krizhevsky et al. (2013)

Deep Convolutional Neural Network

Want to know more about state-of-the-art neural networks?

CS 231N

<http://vision.stanford.edu/cs231n/>

Winter QT 2015

Fei-Fei Li & Andrej Karpathy

Object Recognition: Building Features and Invariance

visual processing is done in stages

each area performs a transformation on its inputs

invariance is built gradually across many successive steps

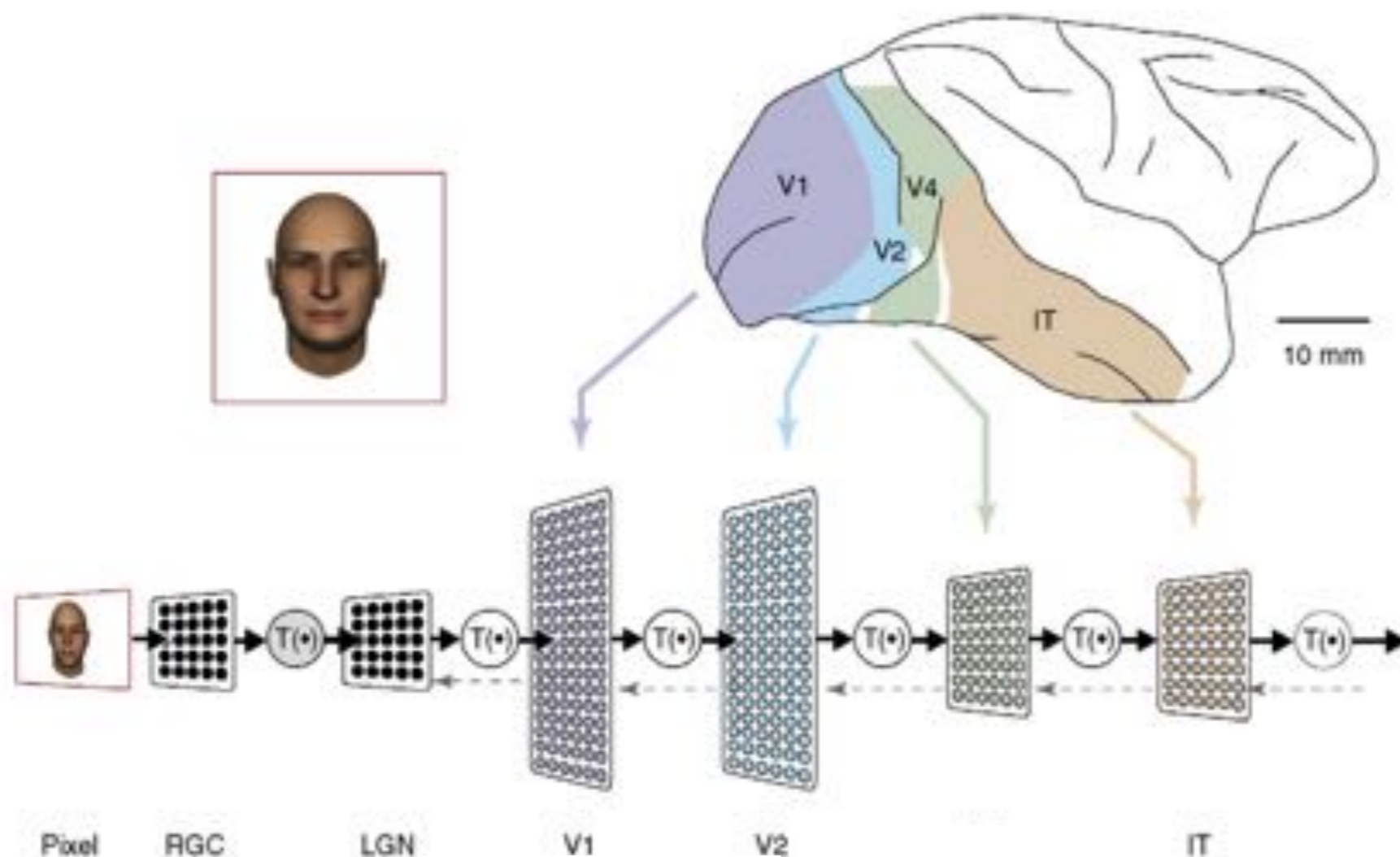

DiCarlo & Cox (2007)

Feed-Forward Object Recognition Model

biologically-inspired processing pipeline

patches — receptive fields
building invariance
hierarchical processing

major drawbacks?

no feedback

much less complex than human vision

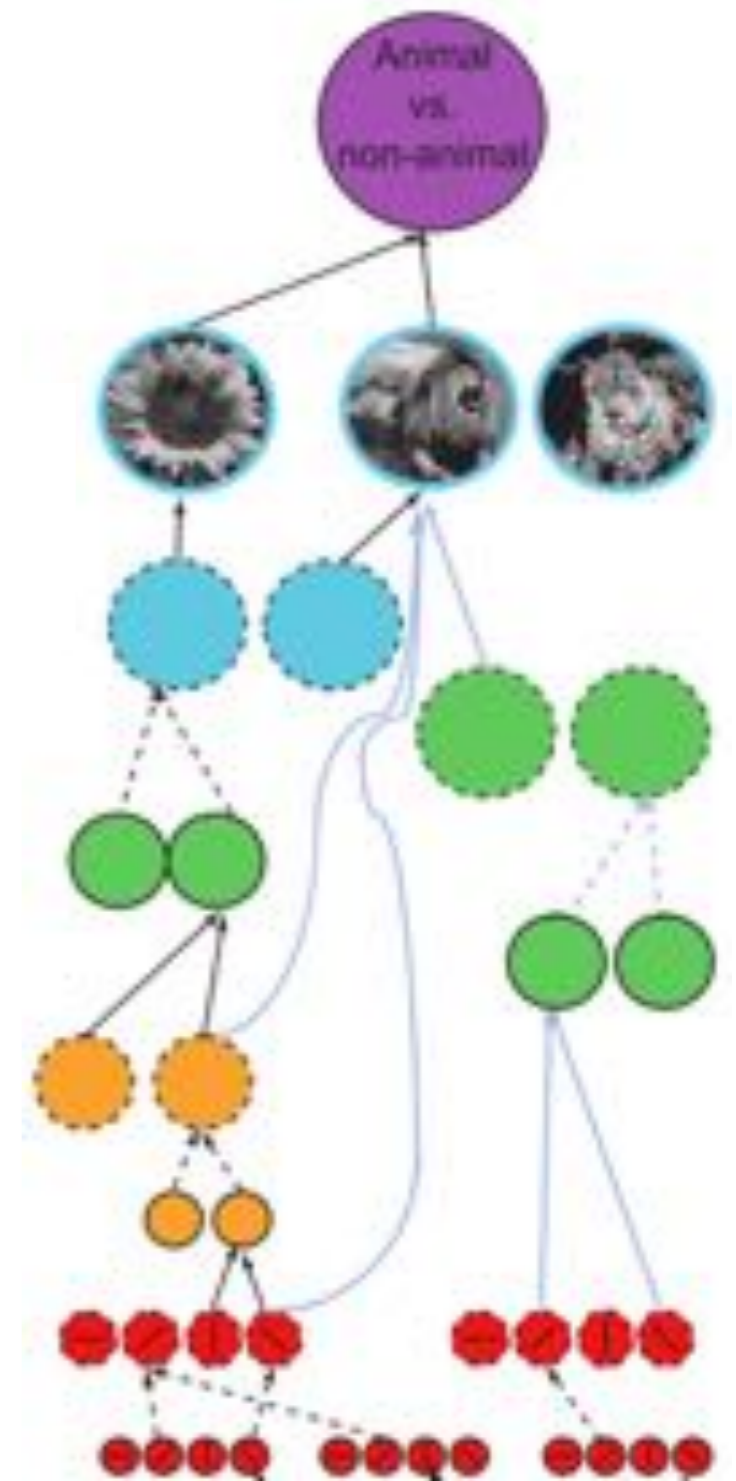

Serre et al. (2007)

Deep Convolutional Neural Network

extremely large scale data and computation

sudden, huge performance boost for recognition

if you want to know more, take CS 231N in Winter QT

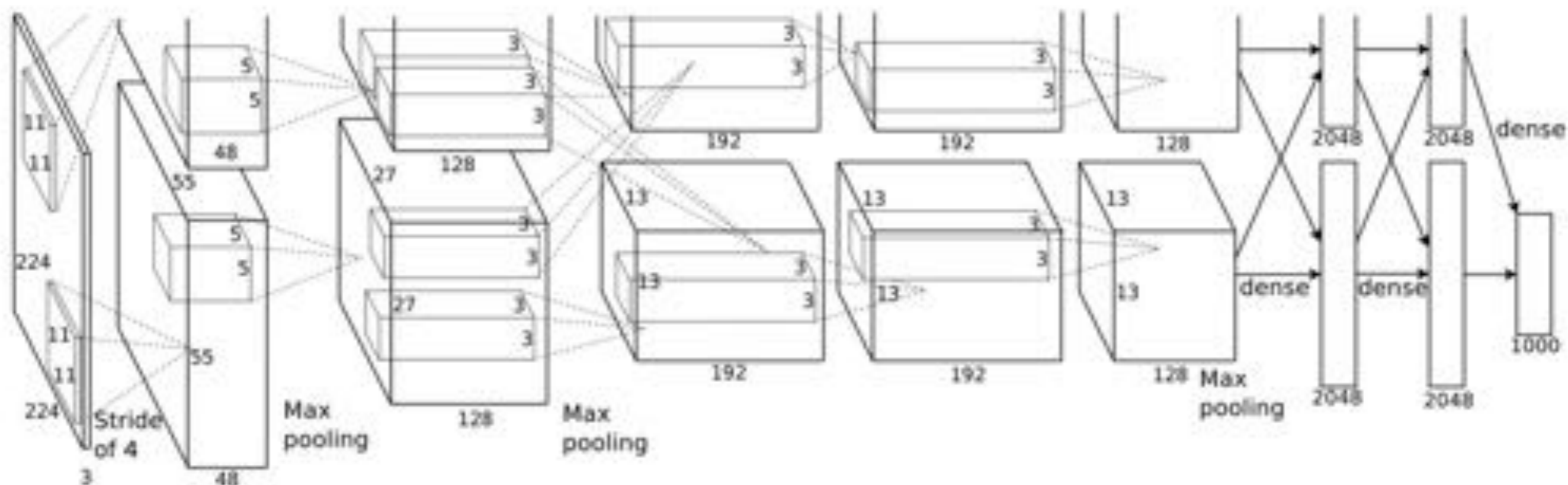

Krizhevsky et al. (2013)

End-Quarter Feedback Forms